

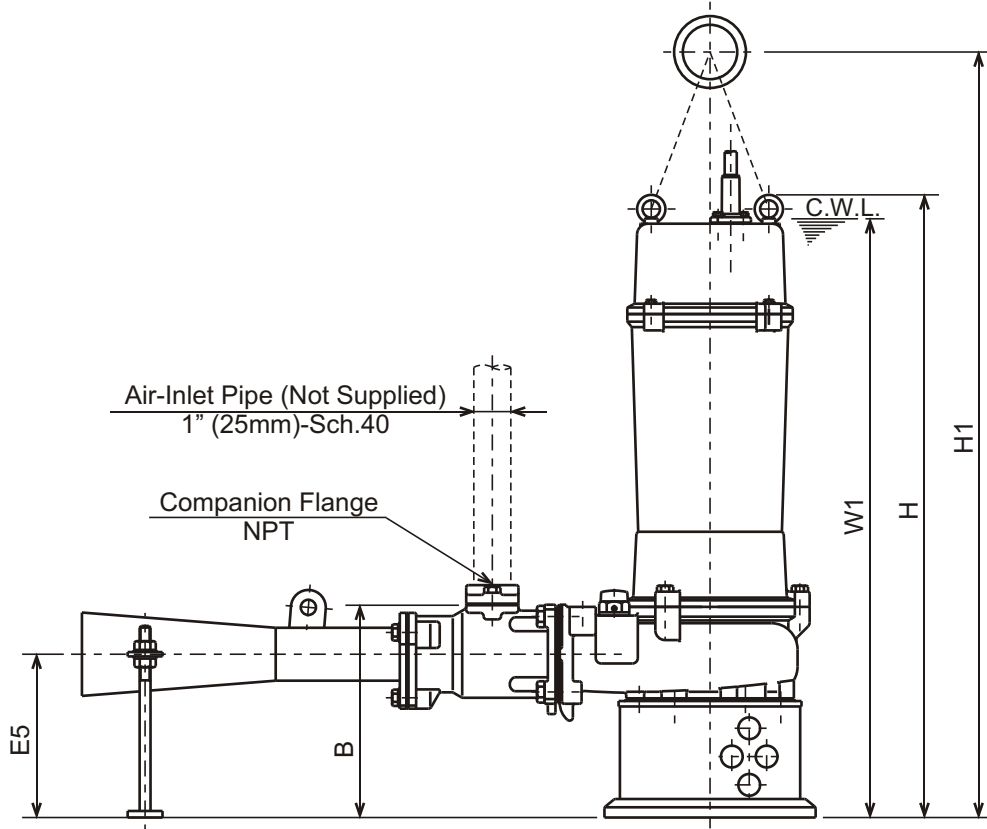

BER - SERIES
SUBMERSIBLE EJECTOR / AERATOR

DIMENSIONS

8-BER5S

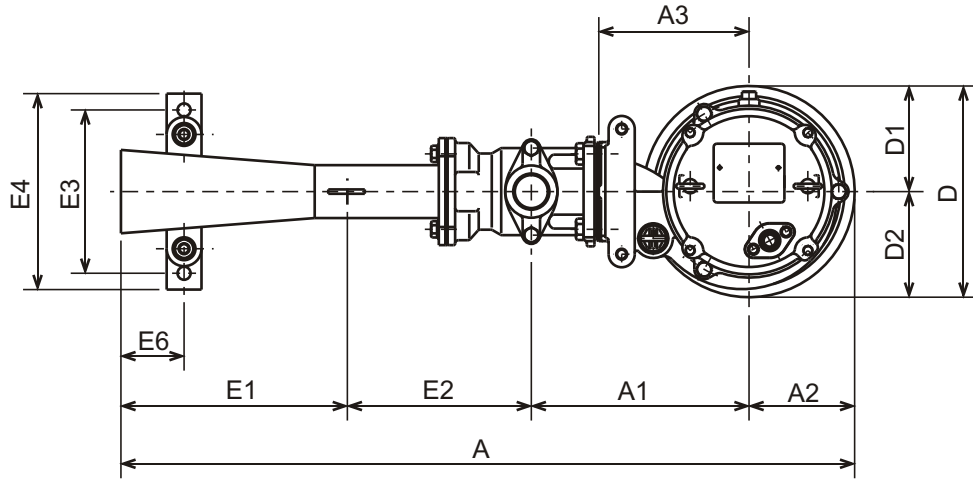

C.W.L. : Continuous running Water Level

DIMENSIONS:USCS (Inch)

Model	HP	Air Inlet Dia.	Ejector Pump & Motor															C.W.L. W1	*Wt. (lbs.)	
			A	A1	A2	A3	B	D	D1	D2	H	H1	E1	E2	E3	E4	E5			E6
8-BER5S	1	1"	26 9/16	7 7/8	3 13/16	5 7/16	7 11/16	7 5/8	3 13/16	3 13/16	22 1/2	27 3/4	8 3/16	6 5/8	5 7/8	7 1/16	5 7/8	2 5/16	21 5/8	77

DIMENSIONS:METRIC (mm)

Model	kW	Air Inlet Dia.	Ejector Pump & Motor															C.W.L. W1	*Wt. (kg)	
			A	A1	A2	A3	B	D	D1	D2	H	H1	E1	E2	E3	E4	E5			E6
8-BER5S	0.75	25	674	200	97	138	195	194	97	97	572	705	208	169	150	180	150	58	550	35

*Excluding Cable