

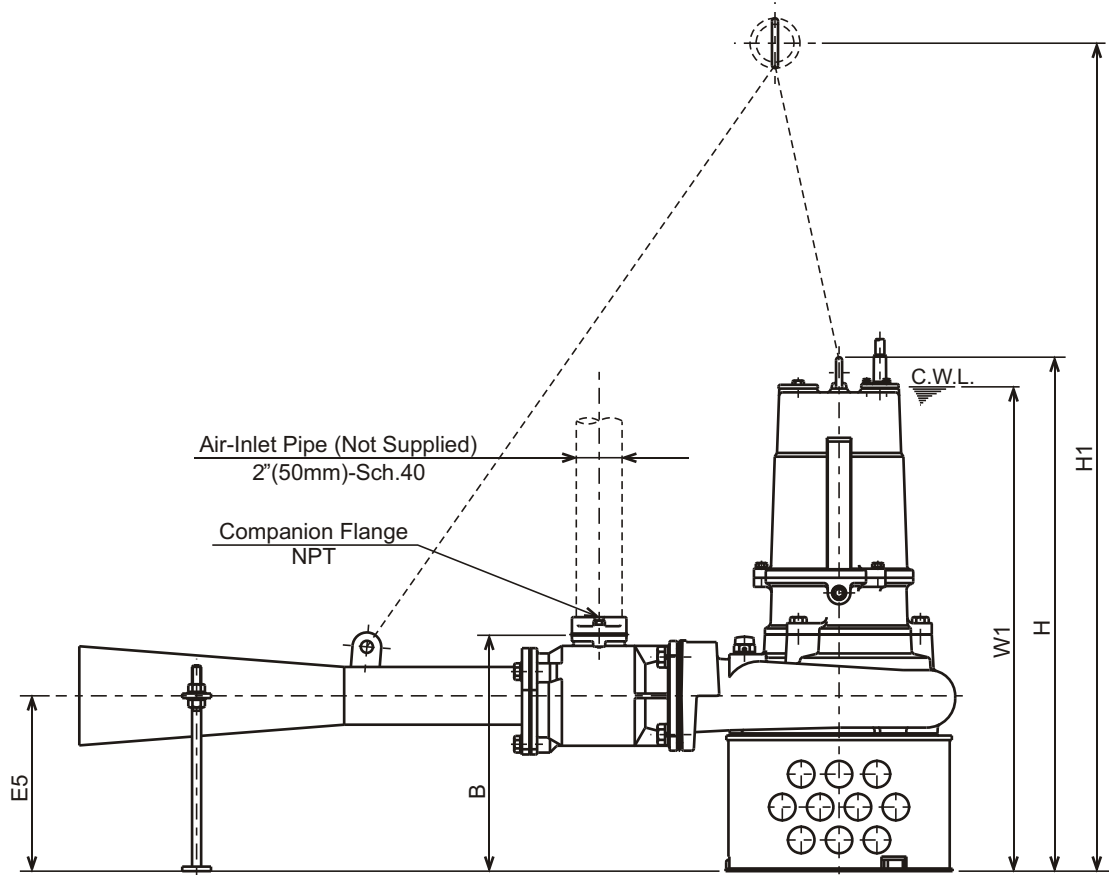

BER - SERIES
SUBMERSIBLE EJECTOR / AERATOR

DIMENSIONS

22-BER5
37-BER5

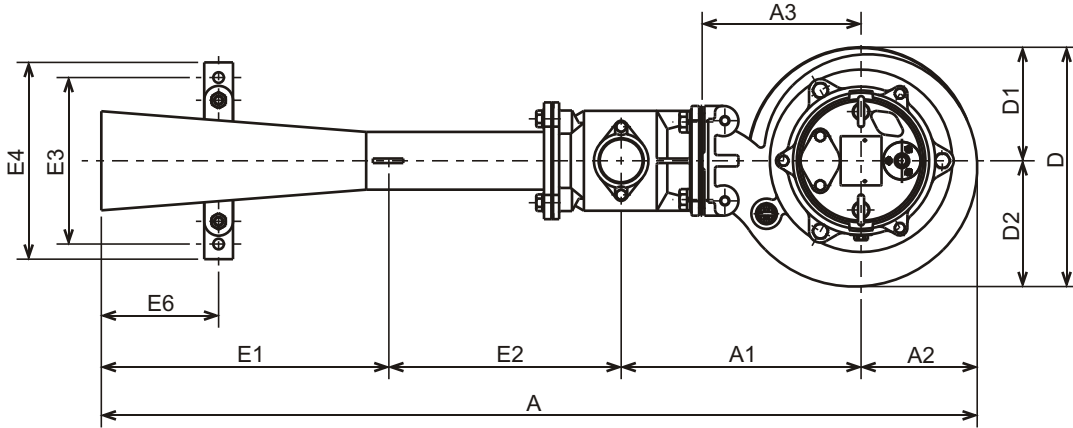

C.W.L. : Continuous running Water Level

DIMENSIONS:USCS (Inch)

Model	HP	Air Inlet Dia.	Ejector Pump & Motor														C.W.L. W1	*Wt. (lbs.)		
			A	A1	A2	A3	B	D	D1	D2	H	H1	E1	E2	E3	E4			E5	E6
22-BER5	3	2"	45 9/16	12 1/2	6 1/16	8 1/4	12 5/16	12 7/16	5 7/8	6 9/16	26 3/4	43 1/16	14 15/16	12 1/16	8 11/16	10 1/4	9 1/8	6 1/8	25 1/4	165
37-BER5	5	2"	45 13/16	12 1/2	6 1/4	8 1/4	12 1/2	12 13/16	5 7/8	6 7/8	29 5/8	45 1/16	14 15/16	12 1/16	8 11/16	10 1/4	9 5/16	6 1/8	28	201

DIMENSIONS:METRIC (mm)

Model	kW	Air Inlet Dia.	Ejector Pump & Motor														C.W.L. W1	*Wt. (kg)		
			A	A1	A2	A3	B	D	D1	D2	H	H1	E1	E2	E3	E4			E5	E6
22-BER5	2.2	50	1158	317	154	210	312	316	150	166	679	1094	380	307	220	260	232	155	640	75
37-BER5	3.7	50	1163	317	159	210	317	325	150	175	753	1145	380	307	220	260	237	155	710	91

*Excluding Cable