

PARTS LIST		SUBMERSIBLE AERATOR			Date: 6/12/2012	
ITEM	PART No.	DESCRIPTION	QTY	SIZE	MATERIAL	NOTES
1	140-035-14	Hex.Bolt	2	M6x20	SUS304	
2	070-107-18	Cable Clamp	1		FC	
3	140-055-10	Hex.Bolt	4	M8x25	SUS304	
4	142-163-18	Spring Washer	4	M8	SUS304	
5	006-126-14	Stuffing Box	1	No.2	FC	
6	001-936-23	Cable Set (32') 60Hz(USA)	1	2PNCT4Cx3.5mm2	KR-2	
7	008-142-12	Mould Cover 60Hz (USA)	1	KR2-7	CR	
8	009-275-18	Compression type Terminal 60Hz(USA)	3	TGNB-5.5(Insulated)	CU	
9	143-085-21	Pan Screw (w/Spring Washer)	1	M4x6	SWRM	
10	009-122-19	Terminal	1	R-3.5-4	CU	
11	072-102-22	Eye Bolt	2	M12	SUS304	
12	142-397-13	Washer		d13xd24x0.1t	SUS304	
	142-398-14	Washer		d13xd24x0.3t	SUS304	
13	140-078-19	Hex.Bolt	4	M10x35	SUS304	
14	142-164-19	Spring Washer	4	M10	SUS304	
15	050-435-16	Motor Bracket	1		FC	
16	122-151-11	O-Ring	1	G-200(199.3xd5.7)	NBR	*
17	142-000-07	Wave Washer	1	6305(d61xd51x4.5t)	SK5	
18	122-244-12	O-Ring	1	61.4xd3.1	NBR	*
19	052-108-13	Bearing	1	6305ZZC3		
20	058-184-11	Lead Wire Protection Plate	1	d90xd224x1.6t	SPHC	
21	143-126-12	Pan Screw (w/Spring Washer/Plain Washer)	2	M4x12	SWRM	
8	053-498-16	Motor Protector 230V-60Hz(USA)	1	KA314-HLXL203	(B.C)	
	053-439-22	Motor Protector 460V-60Hz(USA)	1	KA314-HMXL00	(H.C)	
23	055-000-72	Rotor	1Set			
24	147-067-16	Impeller Key	1	10x8x32l	SUS420	
25	056C1112	Stator 230V-60Hz(USA)	1Set			
	056C1213	Stator 460V-60Hz(USA)	1Set			
26	140-079-10	Hex.Bolt	4	M10x40	SUS304	
27	142-164-19	Spring Washer	4	M10	SUS304	
28	064-000-11	Motor Frame	1		FC	
29	122-151-11	O-Ring	1	G-200(199.3xd5.7)	NBR	*
30	140-032-37	Hex.Bolt	3	M6x15	SWRM	
31	062-223-16	Bearing Fixing Plate	1	d92xd130x4.5t	SS	
32	052-112-10	Bearing	1	6309ZZC3		
33	140-112-16	Hex.Bolt	4	M12x110	SUS304	
34	142-165-10	Spring Washer	4	M12	SUS304	
35	140-099-16	Hex.Bolt	4	M12x40	SUS304	
36	142-165-10	Spring Washer	4	M12	SUS304	
37	060-000-43	Bearing Housing	1		FC	
38	035-113-18	Oil Plug	2	M12x14	SUS304	
39	121-247-12	Packing	2	d12.3xd18x2t	PE	*
40	025-000-61	Mechanical Seal	1	H-40X(E )	SiC	interchangeable with OLD part# 025-000-38
41	143-070-23	Pan Screw	2	M5x6	SWRM	



PARTS LIST		SUBMERSIBLE AERATOR			Date: 6/12/2012	
ITEM	PART No.	DESCRIPTION	QTY	SIZE	MATERIAL	NOTES

## EXPLODED VIEW

50TRN45.5-62

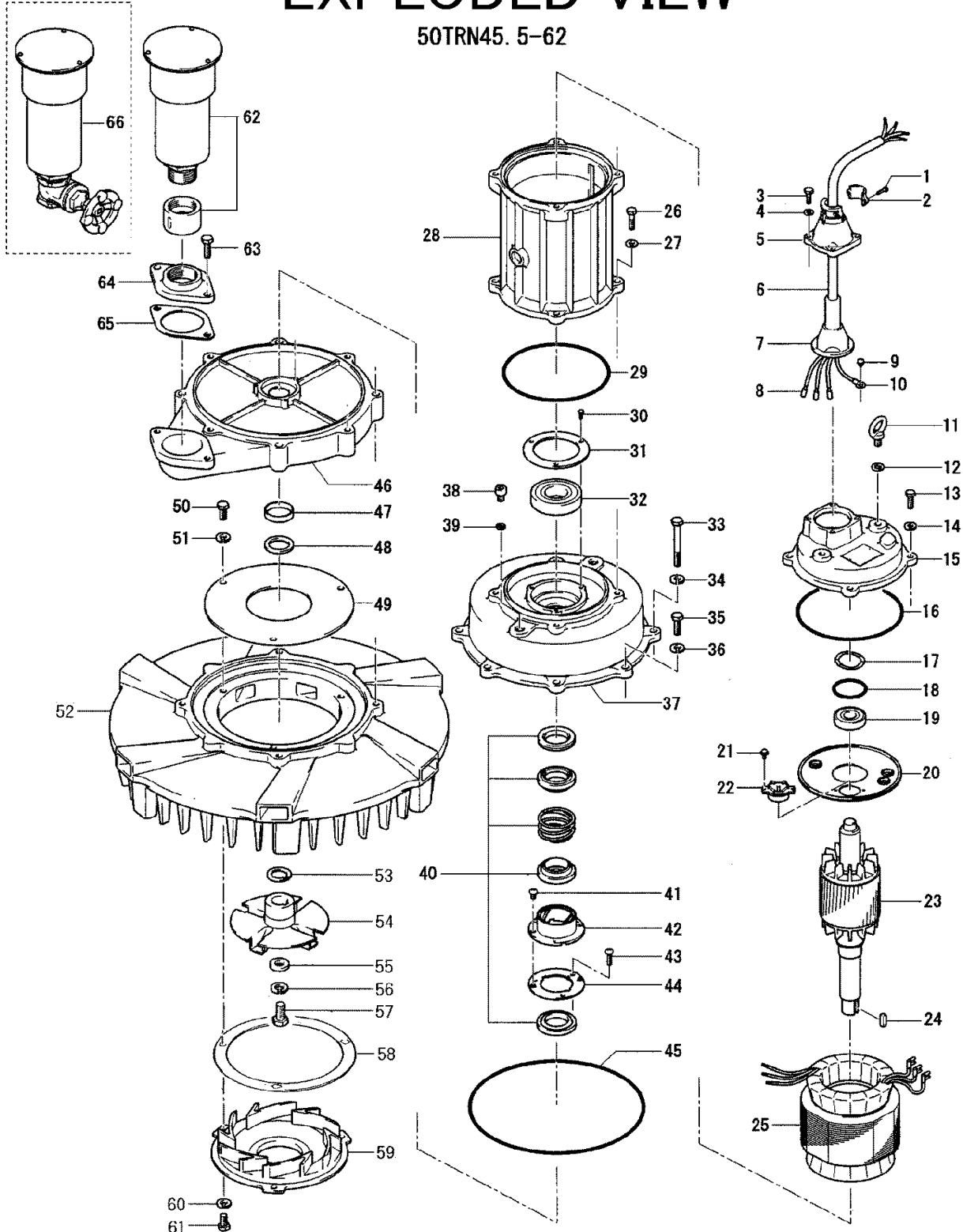

C-00944-1