

GSZ SERIES | High volume dewatering pumps



GSZ5-37-4



GSZ-150-4

Material

Impeller:	High Chrome or Stainless Steel
Casing:	Cast Iron
Mechanical Seal:	Silicon Carbide
Motor Frame:	Cast Iron / Cooling Jacket
Shaft:	420 Stainless Steel
Fasteners:	304 Stainless Steel
Cable:	Chloroprene Sheath

Features

- High Volume Pumping
- 4 Pole, 1800 RPM Motors / 6 Pole, 1200 RPM Motors
- Lower Impeller Tip Speeds for Longer Life
- Rugged Iron Construction
- Anti-Wicking Cable Entrance
- Dual Silicon Carbide Mechanical Seals
- Oil Lifter
- Internal Thermal Motor Protection
- Water Jacket for Motor Cooling

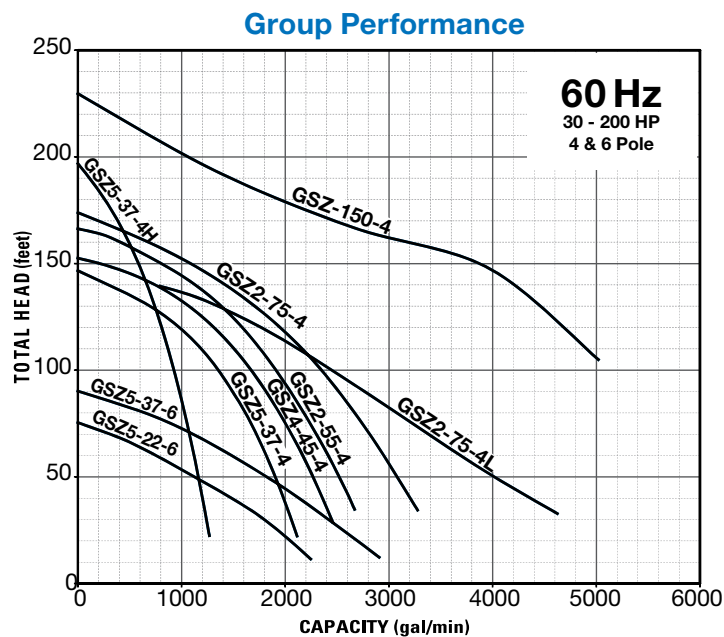

GSZ series is one of the most formidable high volume submersible dewatering pumps available. Reducing impeller speed by half will extend your parts wear life by at least 2-3 times. With impeller materials of High Chrome and Stainless Steel, the GSZ series tackles the most aggressive dewatering applications. The side discharge design allows a smooth passage of abrasive materials.

Tsurumi's exclusive Seal Pressure Relief Ports further protect the mechanical seals on the 4-pole, 1800 RPM models by providing a flow path above the pump casing to allow a release of water to flow from the pump and away from the shaft. The mechanical seals remain isolated in the oil chamber above this flow path and are protected from any excessive pumping pressure or water hammer that may cause premature wear or failure of the mechanical seals in high pressure applications.

Extended operation at low water levels is made possible by utilizing a water jacket that surrounds the motor housing. A portion of the water is allowed to flow completely around the motor on its way to the side discharge. Air lock is prevented by an air-release valve at the top of the water jacket to allow air in the pump casing and water jacket to be displaced by water when the pump begins operation.

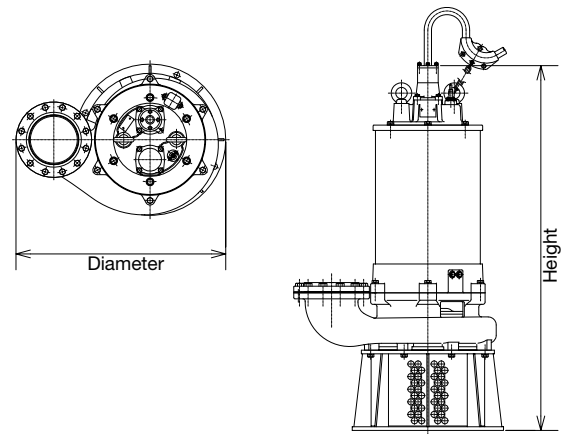

MODEL	MOTOR SPECIFICATIONS					Discharge Size (inch)	DIMENSION		Max. Solids Dia. (inch)	Continuous Running Water Level (in.)	Pump Weight (lbs.)	
	Output (HP)	Rated Current (A)					RPM	Diameter				Height
		208V	230V	460V	575V							
GSZ5-22-6	30	—	—	41	33	1160	8	38	53 9/16	1.97	13 3/4	1610
GSZ5-37-4H	50	—	—	63	49.5	1750	6	35 7/16	61 1/8	0.394	17 3/8	1310
GSZ5-37-4	50	—	—	63	49.5	1750	8	36	62 5/16	0.984	18 7/8	1240
GSZ5-37-6	50	—	—	64	52	1160	8	41 1/4	55 15/16	1.97	14 5/8	1500
GSZ4-45-4	60	—	—	76	63	1745	8	36	62 5/8	0.984	18 1/8	1300
GSZ2-55-4	75	—	—	97	76	1775	10	41 5/16	75 7/8	0.984	20 1/8	2430
GSZ2-75-4	100	—	—	128	101	1775	10	41 5/16	75 7/8	0.984	20 1/8	2680
GSZ2-75-4L	100	—	—	128	101	1775	10	41 5/16	77 5/8	0.984	28 3/4	2730
GSZ-150-4	200	—	—	265	-	1775	10	47 15/16	95 1/4	0.984	30 3/4	5140