

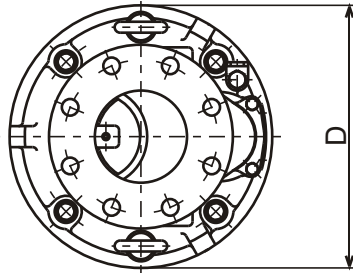

**LH - SERIES
DEWATERING PUMPS**

DIMENSIONS



**LH47.5-61
LH411-61**

4" JIS10K (150PSI) Flange
with
4" NPT Companion Flange

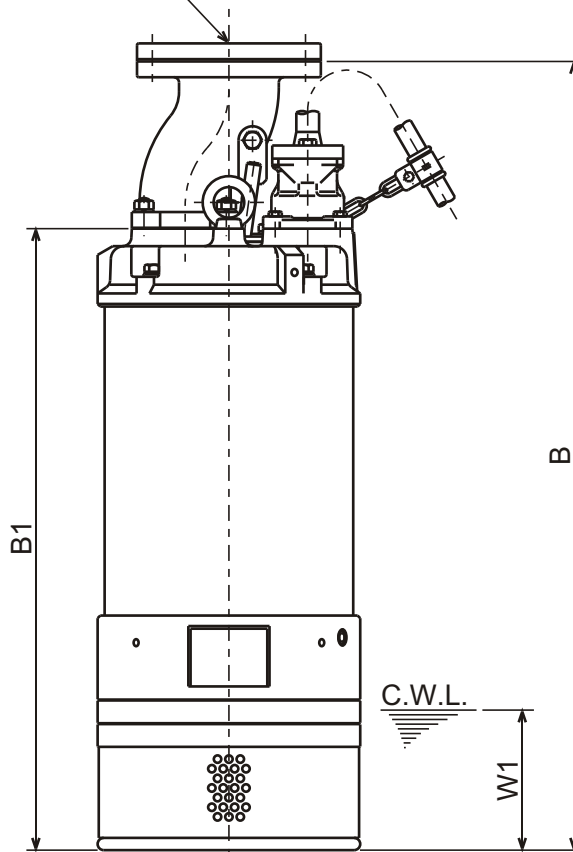

C.W.L. : Continuous running Water Level

DIMENSIONS:USCS (Inch)

Model	HP	NOM. SIZE	Pump & Motor			C.W.L. W1	Wt. (lbs.)
			B	B1	D		
LH47.5-61	10	4"	35 1/2	27 15/16	11 13/16	6 1/4	287
LH411-61	15	4"	35 1/2	27 15/16	11 13/16	6 1/4	302

DIMENSIONS:METRIC (mm)

Model	kW	NOM. SIZE	Pump & Motor			C.W.L. W1	Wt. (kg)
			B	B1	D		
LH47.5-61	7.5	100	901	710	300	160	130
LH411-61	11	100	901	710	300	160	137