

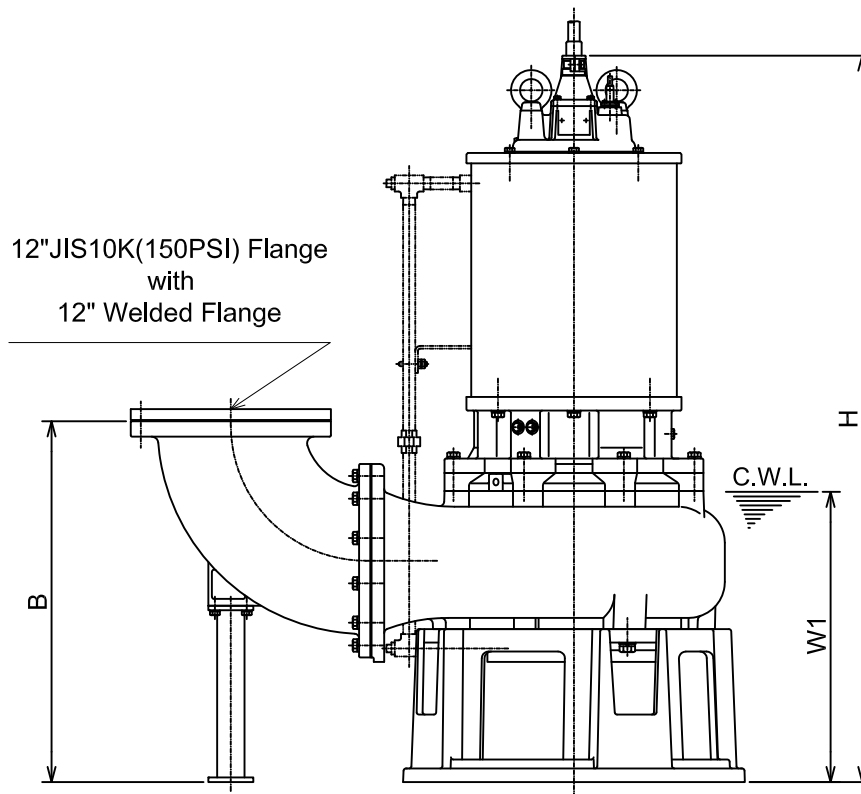

B-SERIES
SEWAGE & WASTEWATER PUMPS

DIMENSIONS

300BK622 -63

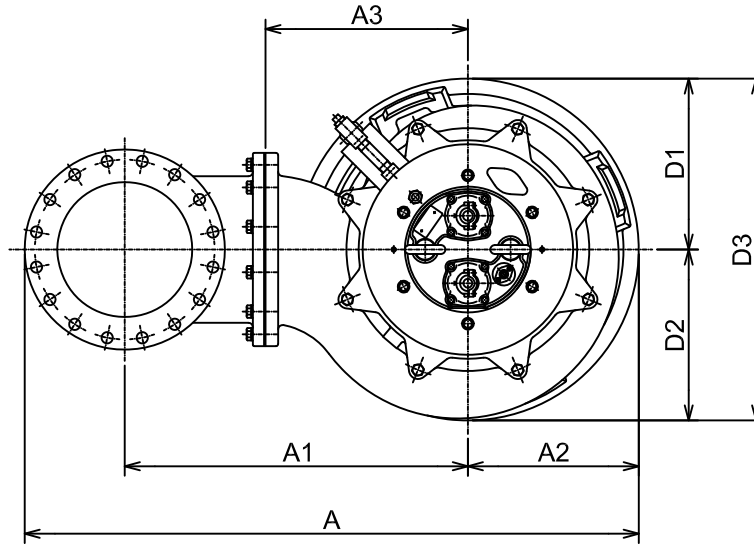

C.W.L. :Continuous running Water Level

DIMENSIONS:USCS(Inch)

Model	HP	NOM. SIZE	Pump & Motor								C.W.L.	*Wt.	
			A	A1	A2	A3	B	D	D1	D2	H	W1	(lbs.)
300BK622 -63	30	12"	53 3/4	30 1/16	14 15/16	17 11/16	31 9/16	29 15/16	14 15/16	14 15/16	63 9/16	25 1/4	1950

DIMENSIONS:METRIC(mm)

Model	kW	NOM. SIZE	Pump & Motor								C.W.L.	*Wt.	
			A	A1	A2	A3	B	D	D1	D2	H	W1	(kg)
300BK622 -63	22	300	1366	763	380	450	802	760	380	380	1615	645	885

*Excluding Cable