

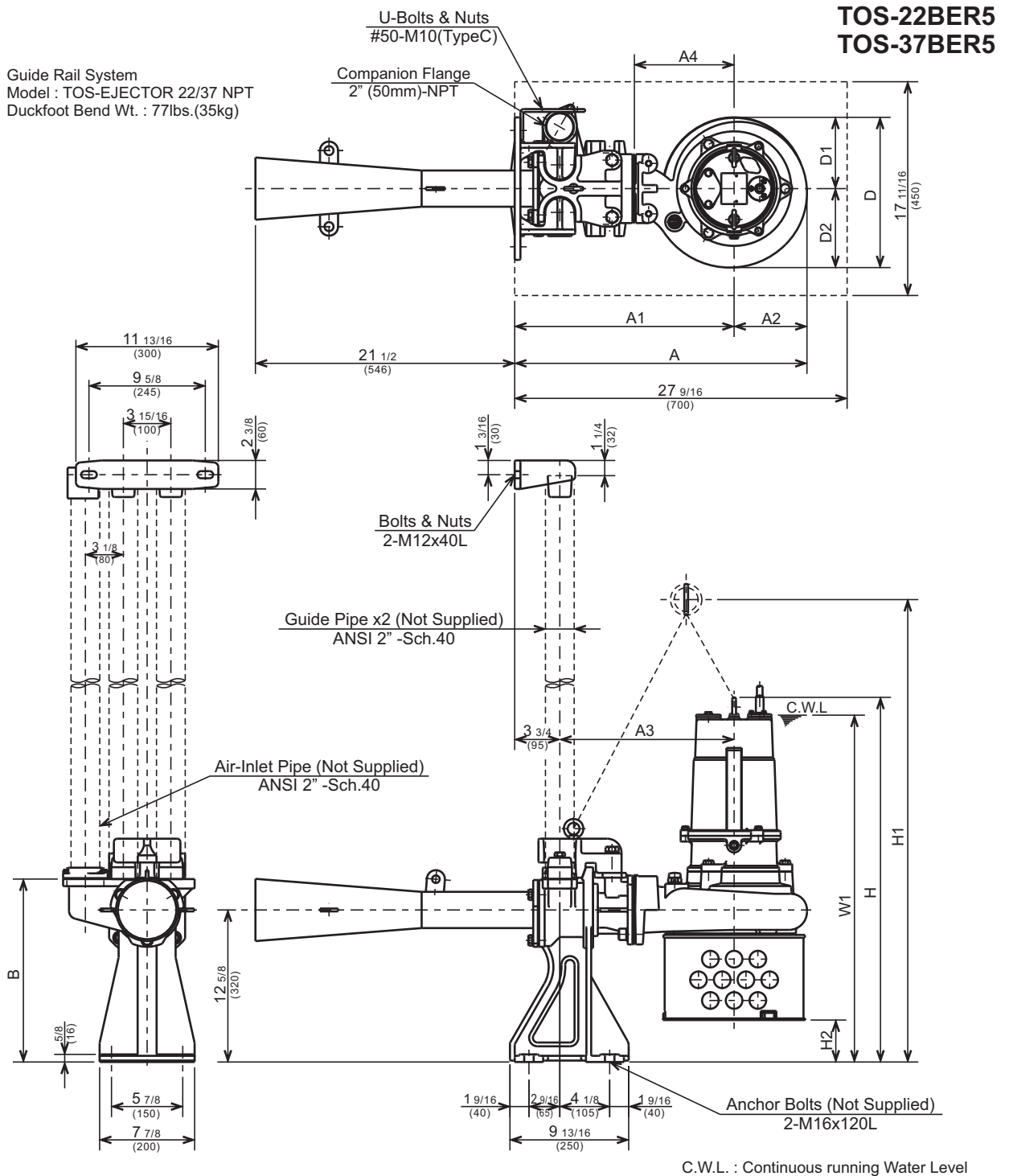

BER - SERIES
SUBMERSIBLE - EJECTOR / AERATOR

DIMENSIONS



DIMENSIONS:USCS (Inch)

Model	HP	Air-Inlet Dia.	Ejector Pump & Motor												C.W.L.	*Wt. (lbs.)
			A	A1	A2	A3	A4	B	D	D1	D2	H	H1	H2		
TOS-22BER5	3	2"	24 1/4	18 3/16	6 1/16	14 7/16	8 1/4	15 3/16	12 7/16	5 7/8	6 9/16	30 3/16	38 5/16	3 7/16	28 3/4	134
TOS-37BER5	5	2"	24 7/16	18 3/16	6 1/4	14 7/16	8 1/4	15 3/16	12 13/16	5 7/8	6 7/8	32 15/16	41 1/4	3 1/4	31 1/4	170

*Excluding Cable & Guide Rail System

DIMENSIONS:METRIC (mm)

Model	kW	Air-Inlet Dia.	Ejector Pump & Motor												C.W.L.	*Wt. (kg)
			A	A1	A2	A3	A4	B	D	D1	D2	H	H1	H2		
TOS-22BER5	2.2	50	616	462	154	367	210	385	316	150	166	767	973	88	730	61
TOS-37BER5	3.7	50	621	462	159	367	210	385	325	150	175	836	1048	83	795	77