

TO150BK437 -63

Guide Rail System : TO-150
Weight : 132lb. (60kg)

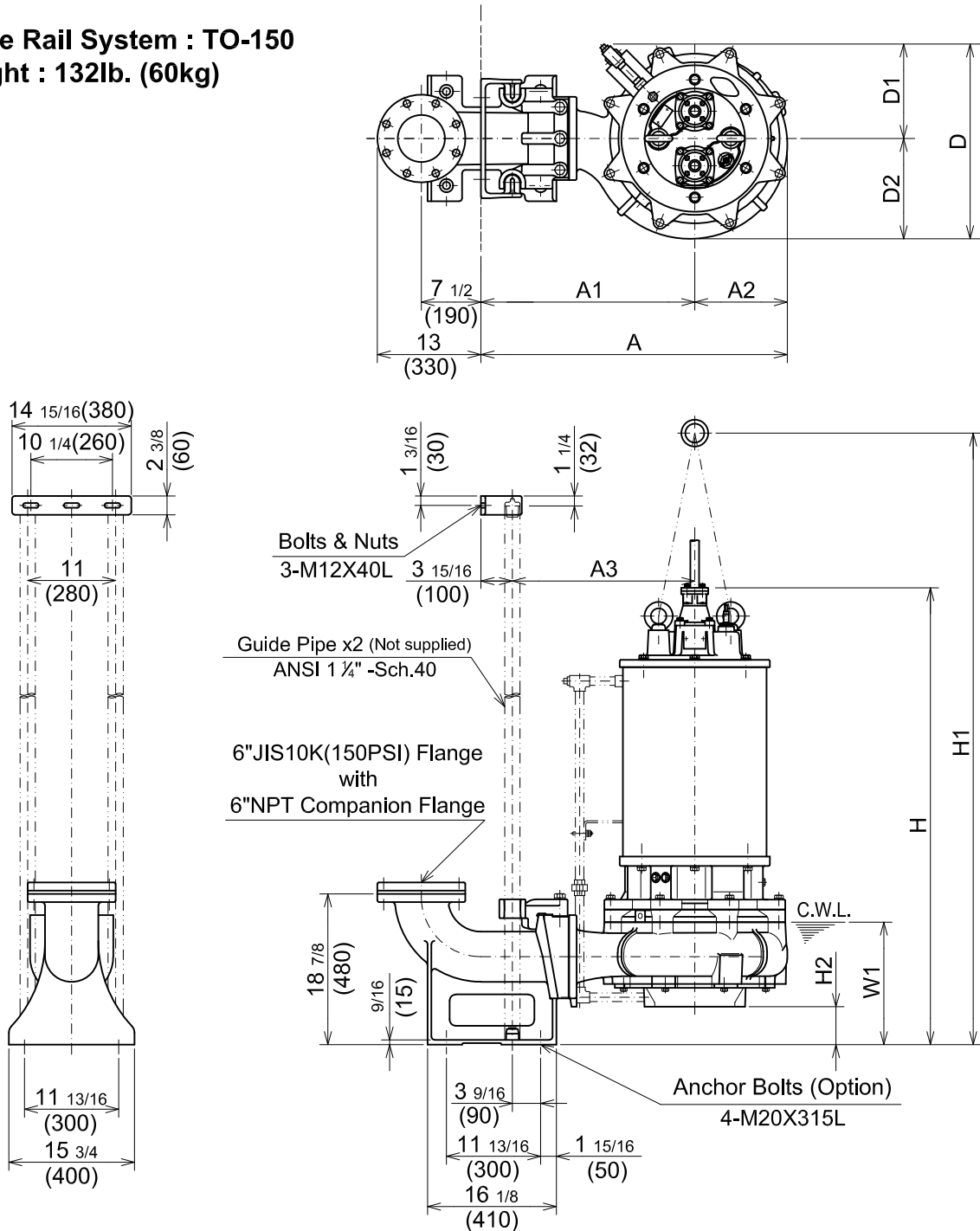

C.W.L. :Continuous running Water Level

DIMENSIONS:USCS (Inch)

Model	HP	NOM. SIZE	Pump & Motor										C.W.L. W1	*Wt. (lbs.)
			A	A1	A2	A3	D	D1	D2	H	H1	H2		
TO150BK437-63	50	6"	38 7/16	26 13/16	11 5/8	22 13/16	24 7/16	11 7/8	12 5/8	57 1/16	76 7/16	4 3/4	15 3/8	1570

DIMENSIONS:METRIC (mm)

Model	kW	NOM. SIZE	Pump & Motor										C.W.L. W1	*Wt. (kg)
			A	A1	A2	A3	D	D1	D2	H	H1	H2		
TO150BK437-63	37	150	976	681	295	580	621	301	320	1449	1942	121	390	710

*Excluding TO & Cable