



TSURUMI PUMP

**C-SERIES
CUTTER - TYPE - SEWAGE & WASTEWATER PUMPS**

DIMENSIONS

150C611-CR -61

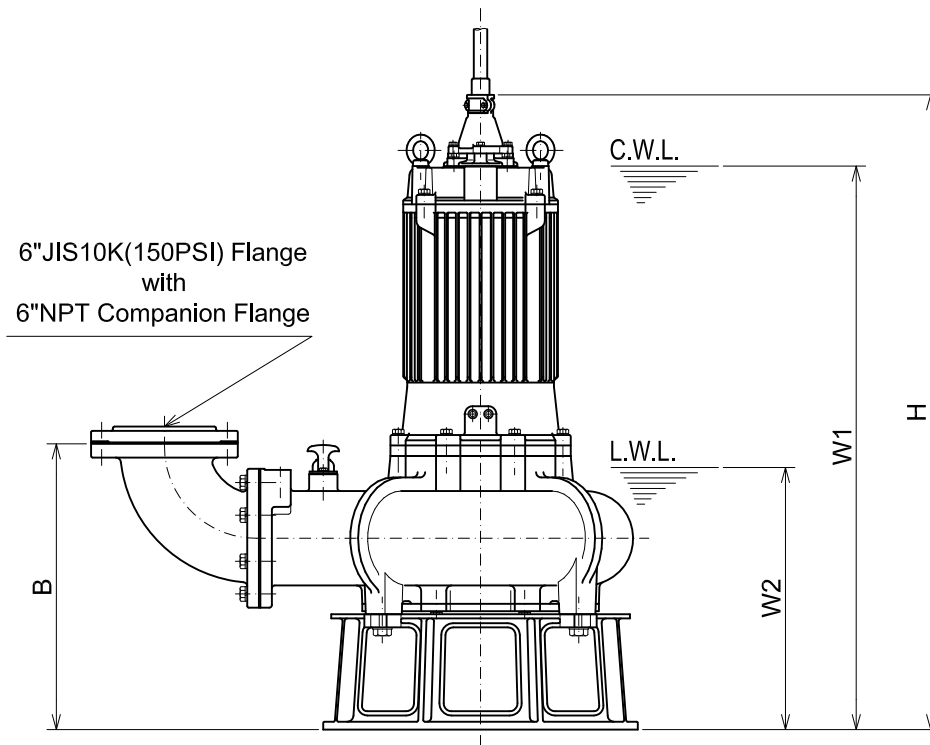
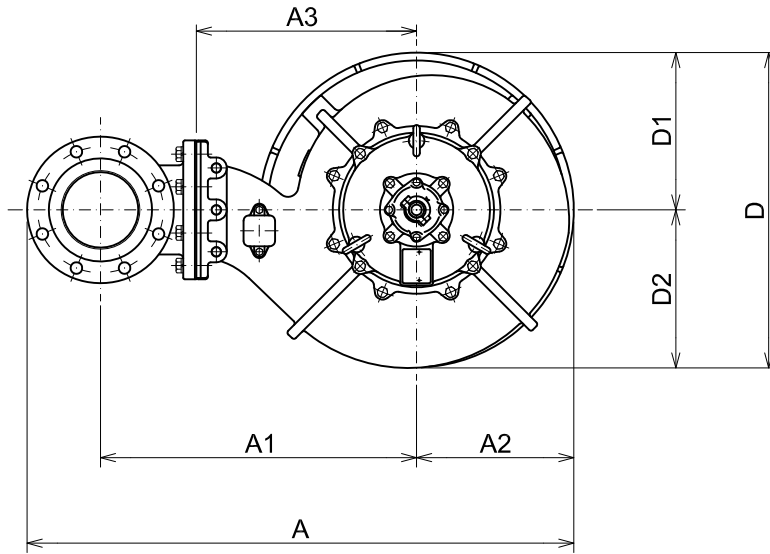

C.W.L. :Continuous running Water Level
L.W.L. :Lowest running Water Level

DIMENSIONS:USCS(Inch)

Model	HP	NOM. SIZE	Pump & Motor									C.W.L.	L.W.L.	Wt. (lbs.)
			A	A1	A2	A3	B	D	D1	D2	H			
150C611-CR -61	15	6"	41 1/16	23 3/4	11 13/16	16 9/16	21 7/16	23 11/16	11 13/16	11 7/8	47 11/16	42 3/8	19 5/8	950

DIMENSIONS:METRIC(mm)

Model	kW	NOM. SIZE	Pump & Motor									C.W.L.	L.W.L.	Wt. (kg)
			A	A1	A2	A3	B	D	D1	D2	H			
150C611-CR -61	11	150	1043	603	300	420	545	602	300	302	1211	1075	500	430

*Excluding Cable.