

200C615-CR -61

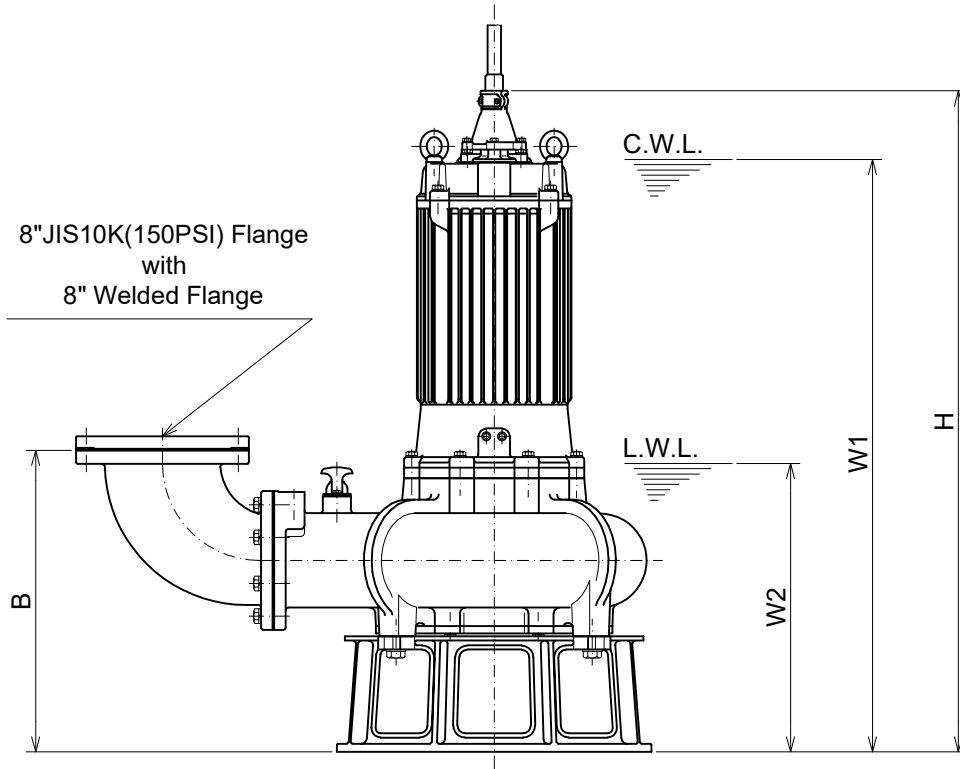
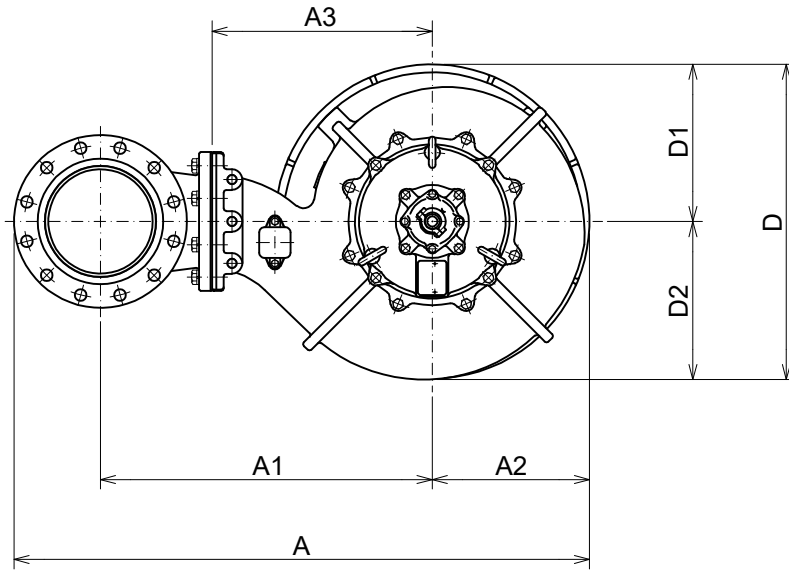

8" JIS10K(150PSI) Flange with 8" Welded Flange

C.W.L. : Continuous running Water Level
L.W.L. : Lowest running Water Level

DIMENSIONS:USCS(Inch)

Model	HP	NOM. SIZE	Pump & Motor									C.W.L.	L.W.L.	*Wt. (lbs.)
			A	A1	A2	A3	B	D	D1	D2	H			
200C615-CR -61	20	8"	43 1/4	24 15/16	11 13/16	16 9/16	22 5/8	23 11/16	11 13/16	11 7/8	49 5/8	44 1/2	21 5/8	1210

*Excluding Cable

DIMENSIONS:METRIC(mm)

Model	kW	NOM. SIZE	Pump & Motor									C.W.L.	L.W.L.	*Wt. (kg)
			A	A1	A2	A3	B	D	D1	D2	H			
200C615-CR -61	15	200	1098	633	300	420	575	602	300	302	1261	1130	550	550