

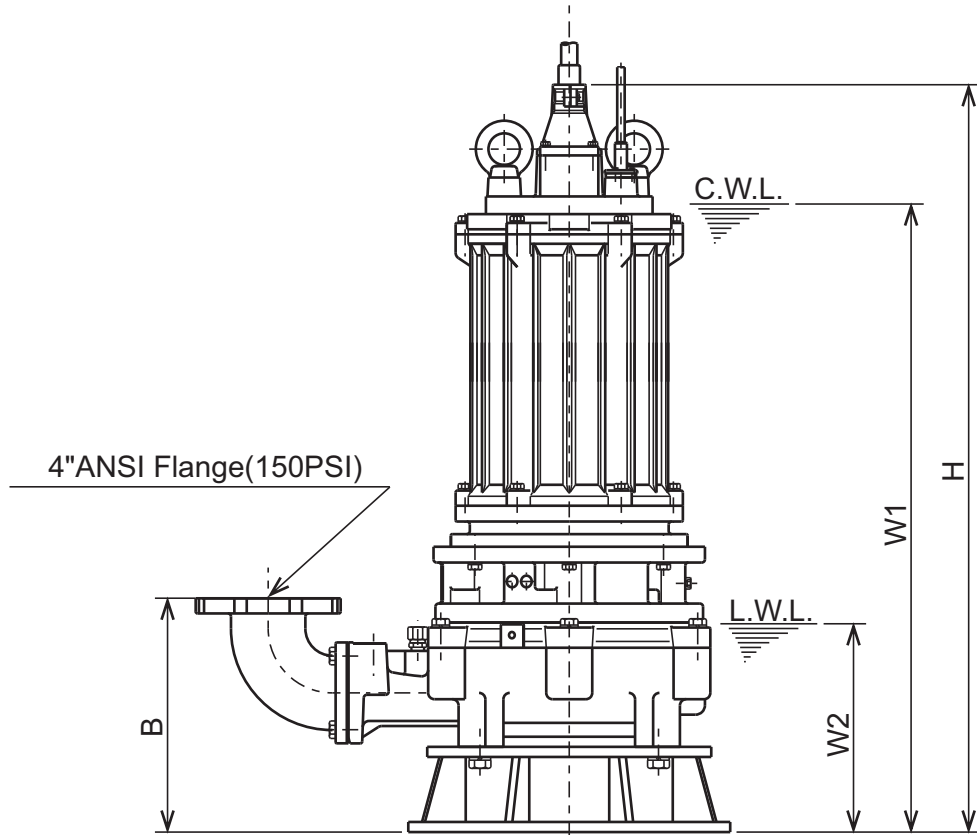

C - SERIES
CUTTER-TYPE - SEWAGE & WASTEWATER PUMPS

DIMENSIONS

Bend Model:
BEND100-100 ANSI

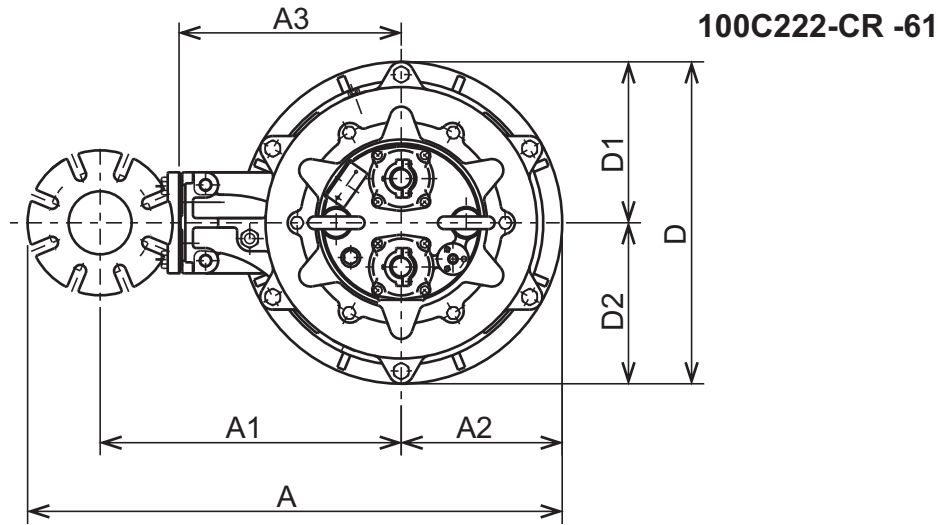

C.W.L. : Continuous running Water Level
L.W.L. : Lowest running Water Level

DIMENSIONS:USCS (Inch)

Model	HP	NOM. SIZE	Pump & Motor								C.W.L.	L.W.L.	Wt. (lbs.)	
			A	A1	A2	A3	B	D	D1	D2	H	W1		W2
100C222-CR-61	30	4"	33 3/4	19 3/16	10 1/16	13 3/4	14 5/8	20 1/16	10 1/16	10 1/16	46 5/8	39 1/8	13	915

*Excluding Cable

DIMENSIONS:METRIC (mm)

Model	kW	NOM. SIZE	Pump & Motor								C.W.L.	L.W.L.	Wt. (kg)	
			A	A1	A2	A3	B	D	D1	D2	H	W1		W2
100C222-CR-61	22	100	857	487	255	350	371	510	255	255	1184	995	330	415