



C - SERIES
CUTTER-TYPE - SEWAGE & WASTEWATER PUMPS

DIMENSIONS

TOS100C222-CR-61

Guide Rail System
TOS-100FH

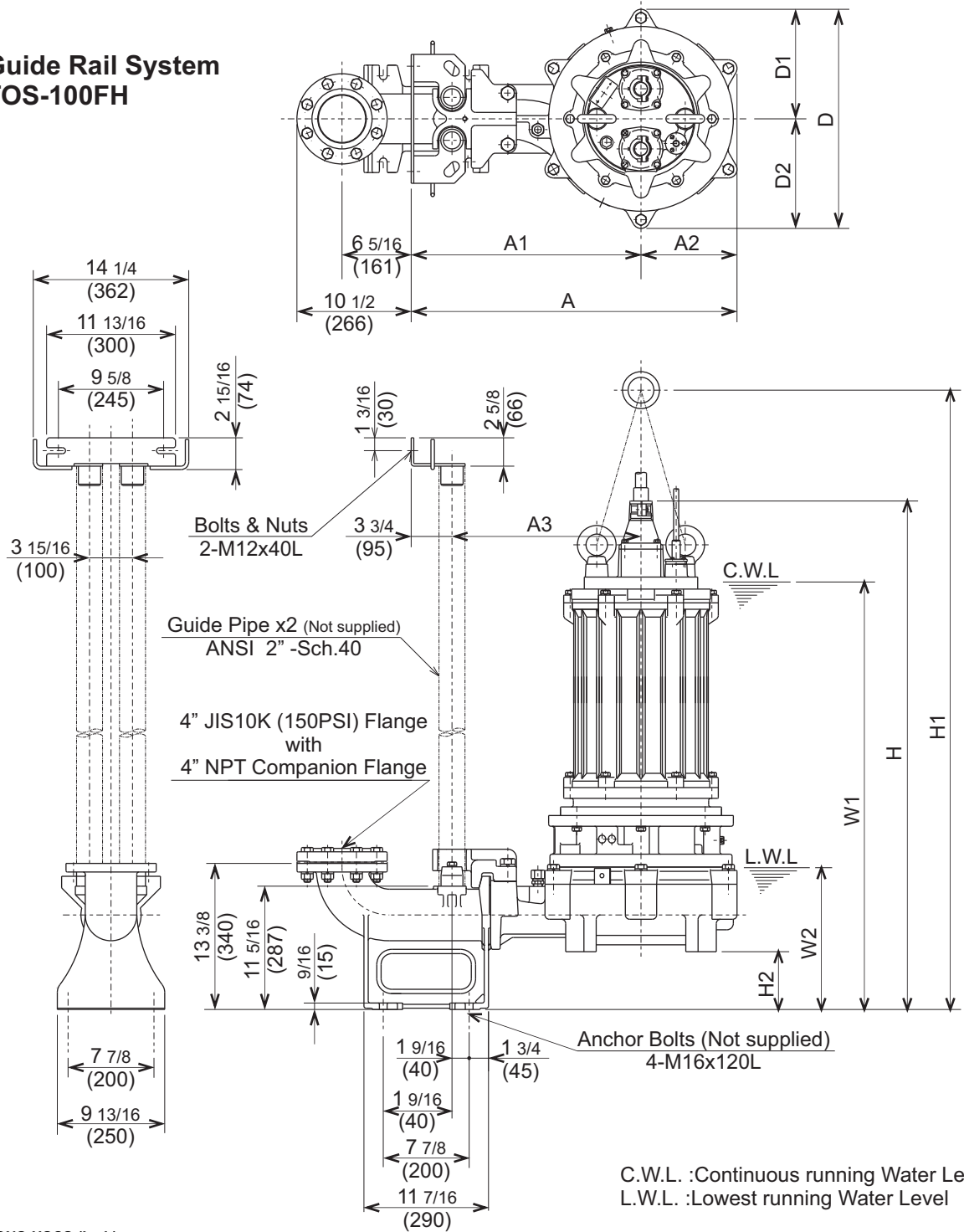

DIMENSIONS:USCS (Inch)

Model	HP	NOM. SIZE	Pump & Motor									C.W.L.	L.W.L.	Wt. (lbs.)	
			A	A1	A2	A3	D	D1	D2	H	H1				H2
TOS100C222-CR-61	30	4"	29 7/8	21 1/16	8 13/16	17 5/16	20 1/16	10 1/16	10 1/16	46 5/8	56 3/4	5 5/16	39 3/16	13	840

DIMENSIONS:METRIC (mm)

Model	kW	NOM. SIZE	Pump & Motor									C.W.L.	L.W.L.	Wt. (kg)	
			A	A1	A2	A3	D	D1	D2	H	H1				H2
TOS100C222-CR-61	22	100	759	535	224	440	510	255	255	1184	1440	135	995	330	380