

Guide rail
Model: TO-200x250
Weight: 353 lbs. (160kg)

TO250BZ455H -61
TO250BZ475H -61

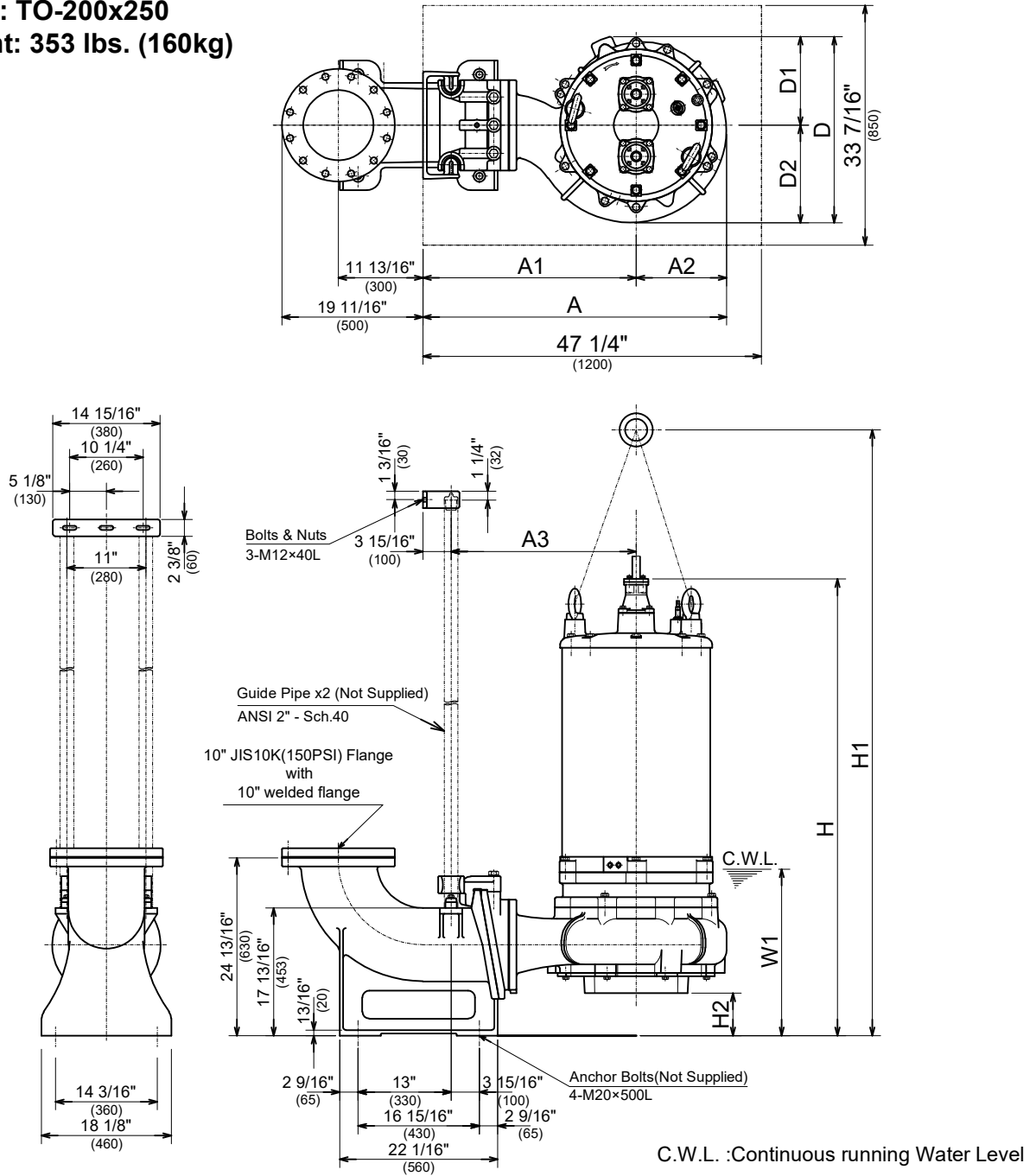

DIMENSIONS:USCS (Inch)

Model	HP	NOM. SIZE	Pump & Motor										C.W.L. W1	*Wt. (lbs.)
			A	A1	A2	A3	D	D1	D2	H	H1	H2		
TO250BZ455H -61	75	10"	42 3/8	29 3/4	12 5/8	25 13/16	26	12 3/8	13 5/8	63 3/4	84 1/2	5 15/16	23 1/4	2840
TO250BZ475H -61	100	10"	42 3/8	29 3/4	12 5/8	25 13/16	26	12 3/8	13 5/8	63 3/4	84 1/2	5 15/16	23 1/4	2840

DIMENSIONS:METRIC (mm)

Model	kW	NOM. SIZE	Pump & Motor										C.W.L. W1	*Wt. (kg)
			A	A1	A2	A3	D	D1	D2	H	H1	H2		
TO250BZ455H -61	55	250	1077	756	321	656	660	314	346	1619	2147	151	590	1290
TO250BZ475H -61	75	250	1077	756	321	656	660	314	346	1619	2147	151	590	1290

*Excluding TOS & Cable