

Guide rail
Model: TO-250
Weight: 353 lbs. (160kg)

TO250BZ455 -61
TO250BZ475 -61

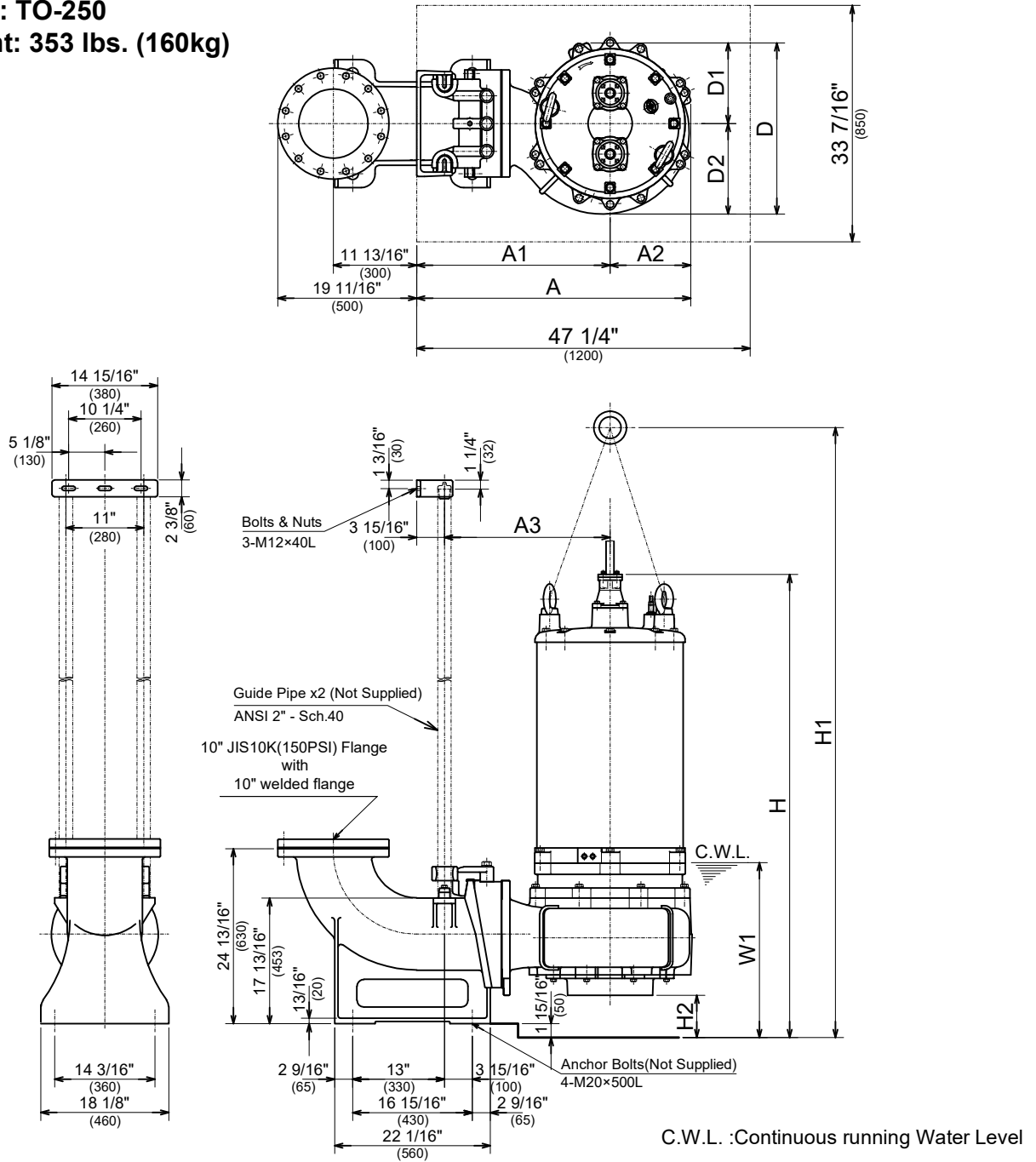

C.W.L. :Continuous running Water Level

DIMENSIONS:USCS (Inch)

Model	HP	NOM. SIZE	Pump & Motor										C.W.L. W1	*Wt. (lbs.)
			A	A1	A2	A3	D	D1	D2	H	H1	H2		
TO250BZ455 -61	75	10"	38 13/16	27 3/8	11 7/16	23 7/16	25 1/16	12 3/16	12 13/16	65 9/16	86 7/16	6	24 3/4	2840
TO250BZ475 -61	100	10"	38 13/16	27 3/8	11 7/16	23 7/16	25 1/16	12 3/16	12 13/16	65 9/16	86 7/16	6	24 3/4	2840

DIMENSIONS:METRIC (mm)

Model	kW	NOM. SIZE	Pump & Motor										C.W.L. W1	*Wt. (kg)
			A	A1	A2	A3	D	D1	D2	H	H1	H2		
TO250BZ455 -61	55	250	986	696	290	596	636	310	326	1666	2195	153	630	1290
TO250BZ475 -61	75	250	986	696	290	596	636	310	326	1666	2195	153	630	1290

*Excluding TOS & Cable