

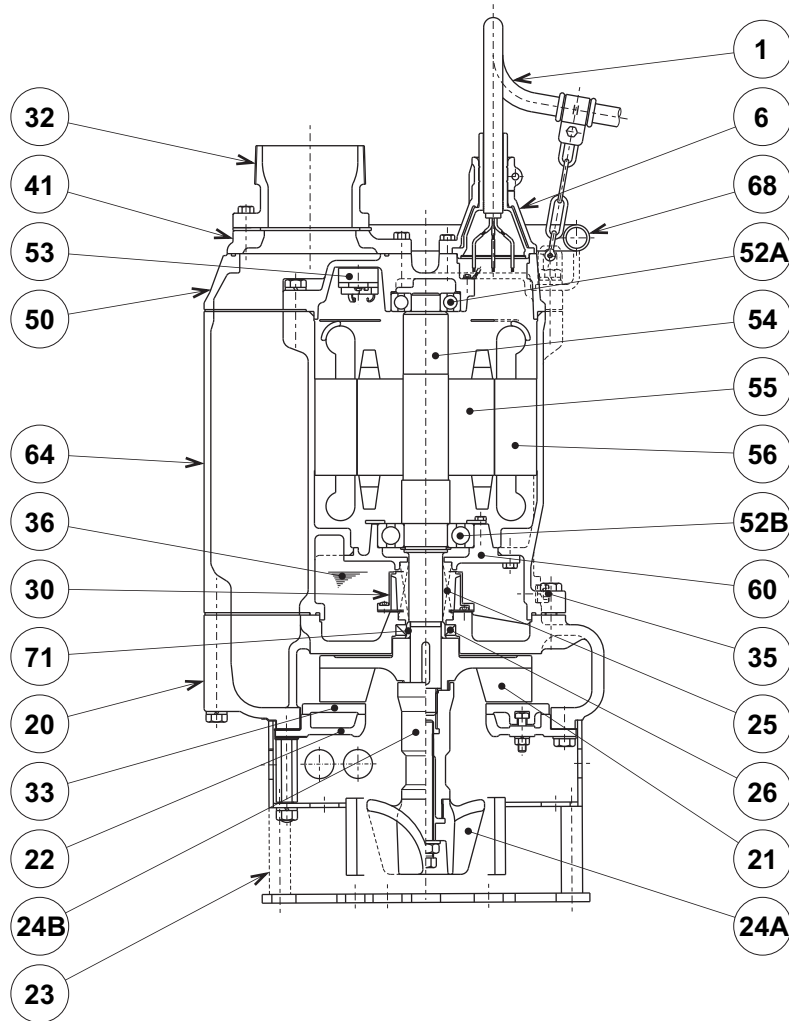

**KRS - SERIES (SAND)
HIGH VOLUME - AGITATOR PUMPS**

SECTIONAL VIEW

KRS2-100



ITEM#	DESCRIPTION	MAIN MATERIAL / NOTE	RELATED ASTM, AISI CODE	RELATED EN CODE	Q'TY
1	Power Cable	Chloroprene Sheath AWG10/4-50ft			1
6	Stuffing Box	Cast Iron	A48M Class30B	EN 1561 GJL-200	1
20	Pump Casing	Cast Iron	A48M Class30B	EN 1561 GJL-200	1
21	Impeller	High Chrome Cast Iron	A532 Class III Type A	DIN 1695 G-X260Cr27	1
22	Suction Cover	Cast Iron	A48M Class30B	EN 1561 GJL-200	1
23	Strainer Stand	Steel (Cold Rolled) + Steel Pipe	A109/A1008 + A53 Type F	EN 10130 + DIN 1615 St33	1
24A	Agitator	High Chrome Cast Iron	A532 Class III Type A	DIN 1695 G-X260Cr27	1
24B	Clutch	Malleable Cast Iron (Hardened)	A47M Grade 22010	EN 1562 GJMB-350-10	1
25	Mechanical Seal	Silicon Carbide / H-35			1
26	Oil Seal	Nitrile Butadiene Rubber / TC-406211			1
30	Oil Lifter	PBT Resin			1
32	Discharge Connection	Cast Iron / NPT 4"	A48M Class30B	EN 1561 GJL-200	1
33	Suction Plate	High Chrome Cast Iron	A532 Class III Type A	DIN 1695 G-X260Cr27	1
35	Oil Plug	Stainless Steel	S 30400	1.4301	1
36	Lubricant	Turbine Oil ISO VG32 or SAE10W/20W			
41	Flange	Cast Iron	A48M Class30B	EN 1561 GJL-200	1
50	Motor Head Cover	Cast Iron	A48M Class25B	EN 1561 GJL-150	1
52A	Upper Bearing	#6306ZZC3			1
52B	Lower Bearing	#6309ZZC3			1
53	Motor Protector				1
54	Shaft	Stainless Steel	S 42000	1.4028	1
55	Rotor				1
56	Stator				1
60	Bearing Housing	Cast Iron	A48M Class25B	EN 1561 GJL-150	1
64	Motor Housing	Cast Iron	A48M Class25B	EN 1561 GJL-150	1
68	Handle	Steel Pipe + Steel	A53 Type F + A283 Grade D	DIN 1615 St33 + EN 10025 S275	1
71	Shaft Sleeve	Stainless Steel	S 40300	1.4000	1