



CORROSION-RESISTANT PUMPS



Submersible Corrosion-Resistant Pumps

Tsurumi Submersible corrosion-resistant pumps are made of stainless steel (304 or 316) and titanium. Because these materials are used, the pumps can handle chemical fluids of low pH value (e.g., corrosive acidic fluid), as well as seawater.

The corrosion-resistant pumps use highly corrosion-resistant materials for all parts that are exposed to fluids, including the impeller, casing, motor frame, outer cover, strainer stand, bend, flange and sealing parts.

Tsurumi puts particular effort into developing submersible pumps made of 316 stainless steel casting. In recent years, polluted water and runoff from mines and quarries have been cited as social problems in many countries, to the point that demand for pumps that can handle these fluids has been increasing year by year. In fact, more than 40% of the runoff from mines is strongly acidic with a pH value of less than 4. To meet this application, Tsurumi has aggressively continued development of all stainless steel pumps that are made of 316 stainless steel casting.

Because they are made of stainless steel casting, the pumps are resistant to wastewater containing abrasive substances, as well as corrosive fluids. That is, these pumps deliver the durability needed in harsh fields where pumps made of aluminium, stainless steel and cast iron suffer damage in a matter of weeks, if not days. More specifically, principal parts of the LH/LH-W-14 and SFQ series are made of 316 stainless steel casting, which considerably improves product reliability in comparison with stainless steel in applications involving heavy-duty work. Therefore, Tsurumi's stainless steel pumps can serve in harsh environments such as mines and quarries, as well as in chemical plants and wastewater treatment plants, thus covering a wide range of applications.

Furthermore, Tsurumi offers seawater pumps that use titanium for parts exposed to fluids. The combination of resin and titanium enables a lightweight compact design that is the most suitable for handling seawater.

Tsurumi continues its research so as to handle a variety of fluids.





Selection Table

		Corrosive Liquids				Seawater
		LH-14	LH-W-14	SQ	SFQ	TM
Discharge Bore	inch	4 - 8	3	2	2 • 3	2 - 3
Motor Output	HP	30 - 150	15 • 30	1/3 - 1	1/2 - 15	1/3 - 5
Discharge Design	Top Discharge, Flow-thru	●	●	●		
	Side Discharge				●	●
Major Wetted Parts		316 Stainless Steel Casting	316 Stainless Steel Casting	304 Stainless Steel	316 Stainless Steel Casting	Titanium
Rubber Parts		FPM (FKM)	FPM (FKM)	Nitrile Butadiene Rubber	FPM (FKM)	Nitrile Butadiene Rubber
Automatic Operation				● (Single-phase only)		●
Guide Rail Fitting System					●	
Page No.		7 - 8		9 - 10		11 - 12

In addition to the target models, Tsurumi's standard material pumps can be made of stainless steel as an option. To request this option, contact your dealer.

pH Values and Corrosion Resistance of Tsurumi Pumps

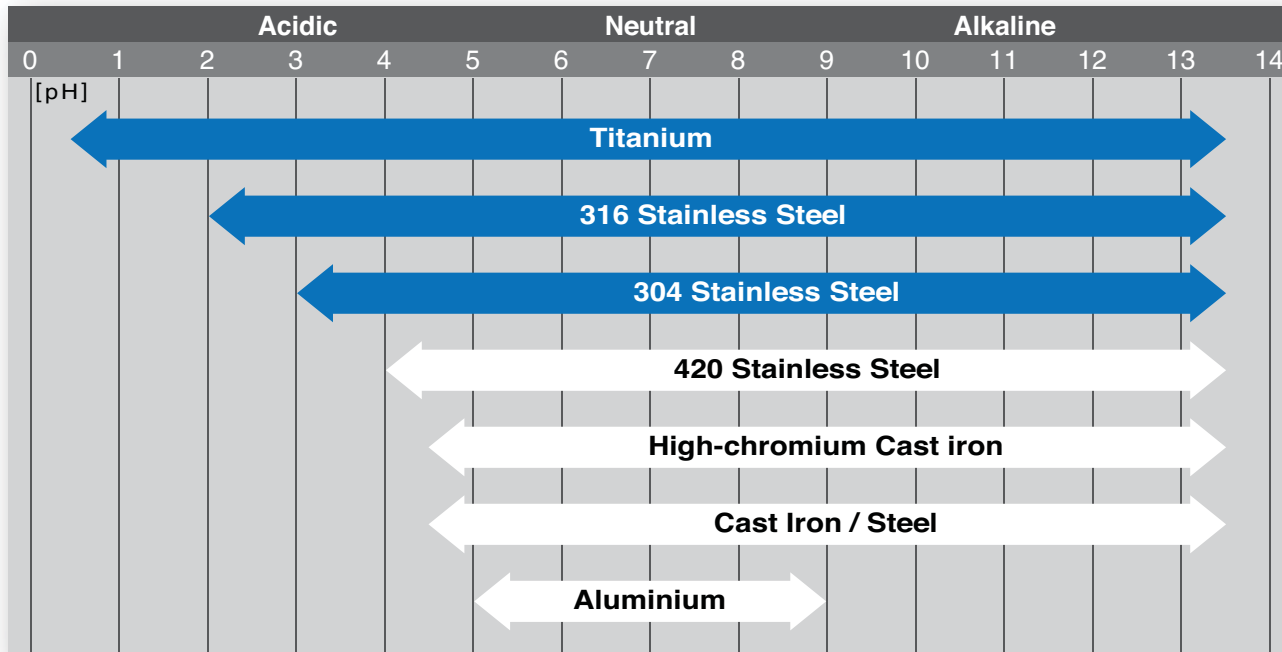

The above data is a rough indication for sulfuric acid (H₂SO₄) and sodium hydroxide (NaOH). Metals are affected by the type of acid/alkali, seal material, painting and abrasive environment.

Special Rubber Parts Made of FPM (FKM) (LH/LH-W-14 & SFQ series only)

Rubber parts of the mechanical seal, oil seal, O-ring and packings are made of FPM (FKM) which provides higher resistance to heat and chemicals.

Automatic Operation (SQ & TM series only)

The automatic model only operates when sufficient water is present. It not only reduces power consumption but also extends the life of wear parts of the pump as it eliminates dry-running that causes early wear-out. The float type automatic model has an integral control circuit and two float switches that operate at a low voltage.



SQ

TM

Guide Rail Fitting System (SFQ-series only)

The guide rail fitting system connects the pump to and from the piping easily just by lowering and hoisting the pump, allowing easy maintenance and inspection without the need to enter the sump.

Accessories

- Duckfoot Bend
- Guide Support
- Guide Hook
- Lifting Chain 16ft. (with Shackles)
- JIS 10kg/cm² Flange



Model Number Designation

LH-14 / LH-W-14 series

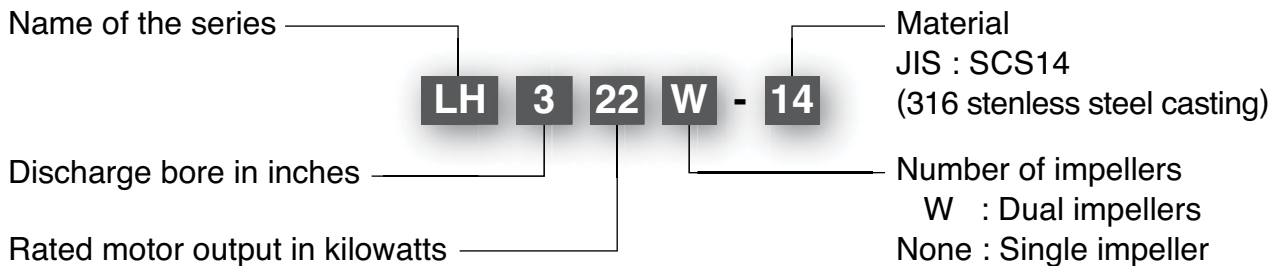

SQ / SFQ / TM series

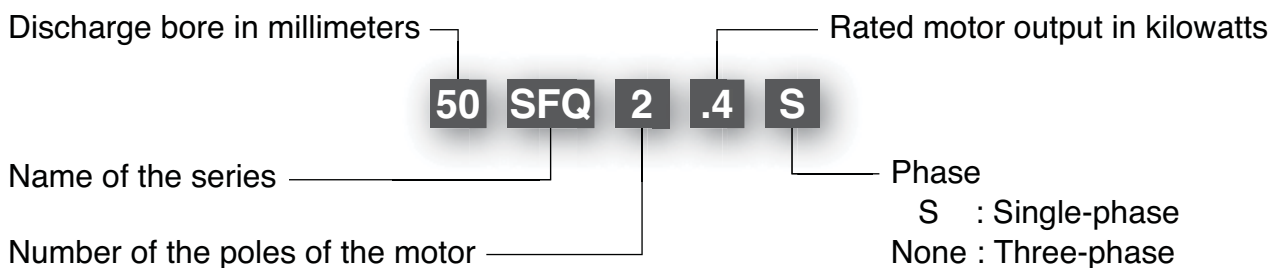

Corrosion-Resistant Material

Parts that are exposed to fluids are made of a highly corrosion-resistant material that protects the pump against corrosion.

LH-14 / LH-W-14 / SFQ series: 316 Stainless Steel Casting
SQ-series: 304 Stainless Steel
TM-series: Titanium

Top Discharge, Flow-thru Design (LH-14 / LH-W-14 / SQ series)

This design provides maximum motor cooling efficiency allowing continuous operation at low water levels and extended dry-run capability, and also allows the shape of the pump to be cylindrical and slim for installation in a well casing for deep well dewatering.

Model
LH8110-14

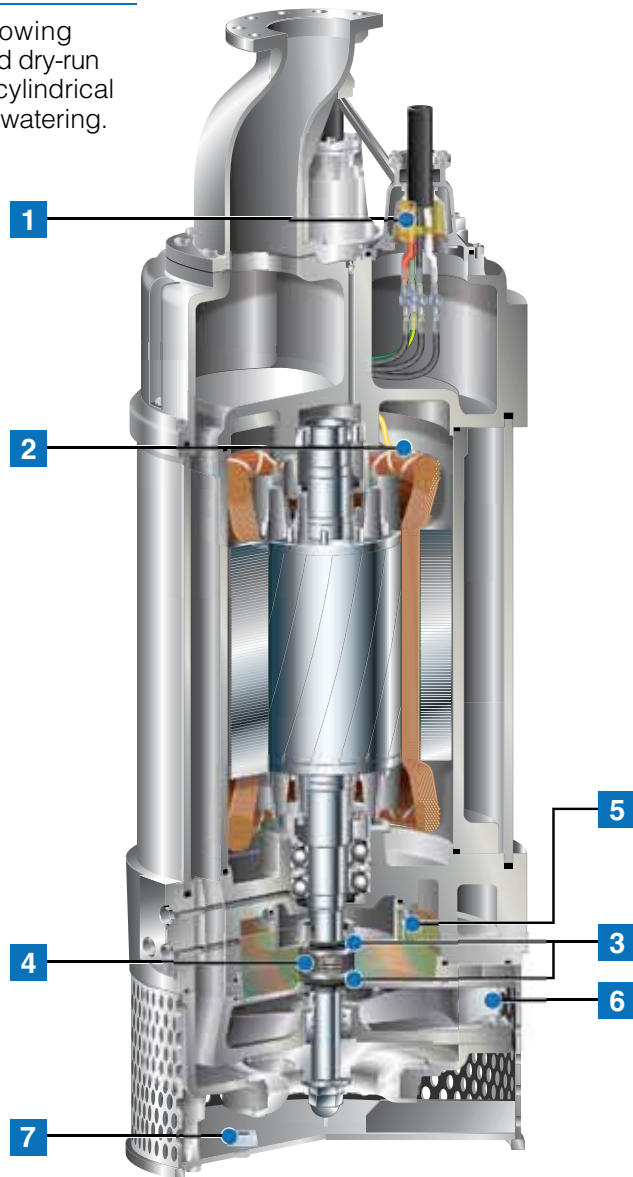

1 Anti-wicking Cable Entry

Prevents water incursion due to capillary wicking should the power cable be damaged or the end submerged.

2 Motor Protector

MTP

Single-phase:

Detects excess heat, therefore, protecting the pump against overheating and dry-running.

Three-phase:

React to excessive heat caused by dry-running. The bimetal strip opens to cause the control panel to shut the power supply.

CTP

Directly cuts the motor circuit if excessive heat builds up or an overcurrent condition occurs in the motor.

3 Dual Inside Mechanical Seals with Silicon Carbide Face

Isolated in the oil chamber where a clean, non-corrosive and abrasion-free lubricating environment is maintained. Compared with the water-cooled outside mechanical seal, it reduces the risk of failure caused by dry-heating and adhering matter. The Silicon carbide provides 5 times higher corrosion, wear and heat resistance than the tungsten carbide. Rubber parts are made of NBR or FPM (FKM) which provides higher resistance to heat and chemicals.

Side Discharge Design (SFQ / TM series)

The pump has a pump casing that facilitates smoother passage of foreign objects in the pumped liquid. It is a simple and practical design that facilitates inspection and repair work.

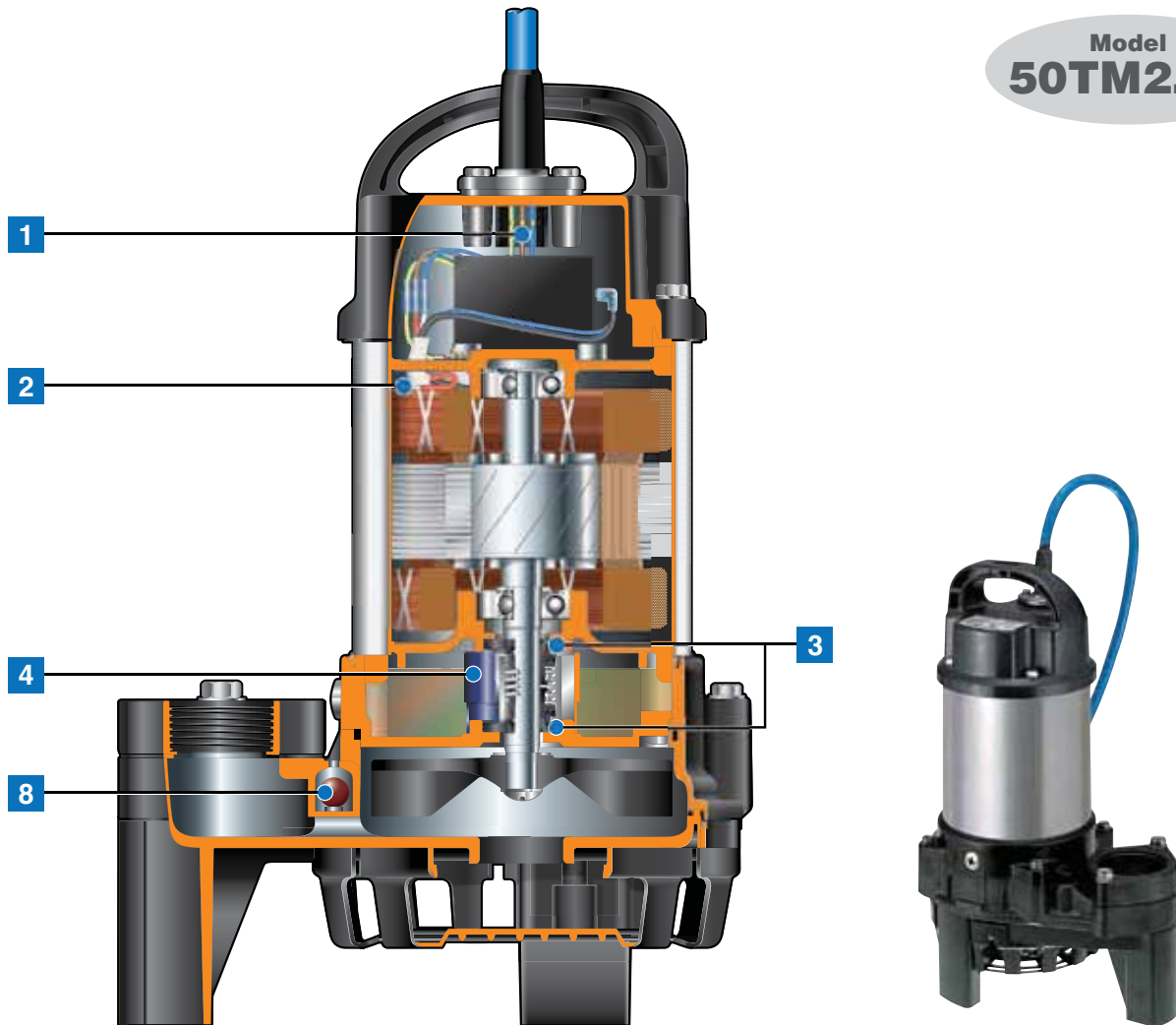

Model
50TM2.4S

4] Oil Lifter [Patented]

Provides lubrication and cooling of the seal faces down to 1/3 of normal oil level, thus maintaining a stable shaft sealing effect and prolonging seal life longer.

5] Leakage Sensor (LH6110-14 and LH8110-14 only)

Detects flooding into the oil chamber that may occur in a worst case scenario. When flooding is detected, signals are sent to operate the indicator lamps through the external control panel.

6] Seal Pressure Relief Ports (LH-14, LH-W-14 and SFQ 7.5HP or over)

Protect the mechanical seal from pump pressure. They also protect the seal face by discharging wear particles.

7] Galvanic Anodes (LH-14 / LH-W-14 series only)

Protect the pump against corrosive potential generated during the drainage of wastewater.

8] Air Release Valve

Fitted on the water jacket, it prevents the Air-lock. When air goes through the valve, the ball stays at the bottom, but when the pumped water starts to flow, it closes the outlet by its buoyancy.

LH-14 -Single Impeller, 316 Stainless Steel Casting-

LH-W-14 -Dual Impellers, 316 Stainless Steel Casting-

The LH/LH-W-14 series is a submersible stainless steel casting high head corrosion-resistant pump designed for handling aggressive and corrosive liquids. The all wetted parts are made of 316 stainless steel, enables it to withstand demanding conditions found in construction, aggregate and mining applications. Being the pump cylindrical and slim, it can be installed in a well casing for deep well dewatering. The center flange construction assures a stable installation even if it is fixed by the discharge pipe. The pump incorporates seal pressure relief ports that prevent the pumping pressure from applying to the shaft seal.



LH637-14



LH8110-14



LH322W-14

Model	Discharge Bore inch	Motor Output HP	Phase	Starting Method	Solids Passage inch	Dimensions Dia x Height inch	Dry Weight* ² lbs	Cable Length ft
LH-14	LH422-14	4	Three	D.O.L.* ¹	0.236	16 9/16 x 53 1/4	815* ³	50
	LH637-14	6		Star-Delta	0.236	20 7/8 x 57	1190* ³	50
	LH6110-14	6		Star-Delta	0.394	23 5/16 x 70 3/8	2980* ³	65
	LH837-14	8		Star-Delta	0.787	20 7/8 x 57	1190* ³	50
	LH8110-14	8		Star-Delta	0.787	23 5/16 x 70 3/8	3090* ³	65
LH-W-14	LH311W-14	3	Three	D.O.L.* ¹	0.334	10 5/8 x 40 5/16	705* ³	65
	LH322W-14	3		D.O.L.* ¹	0.334	13 x 48 5/8	750* ³	65

*¹ Star-Delta available upon request

*² Weights excluding cable

*³ Approximate value

Performance Curves

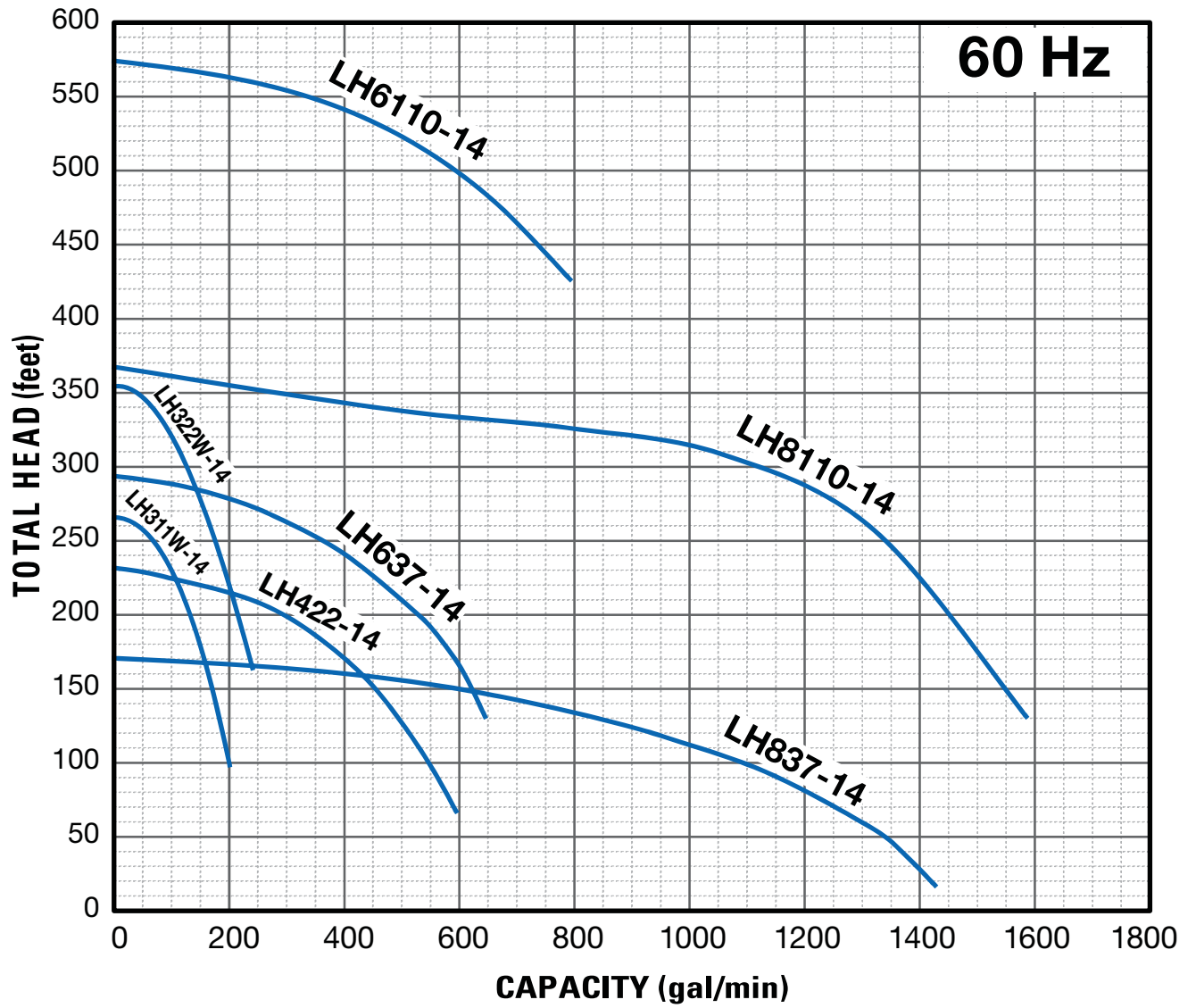

SQ -304 Stainless Steel-

SFQ -316 Stainless Steel Casting-

The SQ-series is a submersible portable stainless steel corrosion-resistant pump designed for handling corrosive liquids. The all wetted parts are made of 304 stainless steel, enables it to withstand demanding conditions found in construction, aggregate and mining applications. Every SQ model is slim design enough to be accommodated in an 8-inch pipe. Liquid paraffin is used for the lubricating oil, which enables the application of the SQ-series to the food or aquaculture industry.

The SFQ-series is a submersible stainless steel casting high head corrosion-resistant pump designed for handling aggressive and corrosive liquids. The all wetted parts are made of 316 stainless steel, enables it to withstand demanding conditions found in construction, aggregate and mining applications. The pump with 7.5HP and above motor incorporates seal pressure relief ports that prevent the pumping pressure from applying to the shaft seal.

**50SQ2.75****80SFQ23.7****100SFQ211**

Model		Discharge Bore inch	Motor Output HP	Phase	Starting Method	Solids Passage 50/60Hz inch	Dimensions Dia x Height inch	Dry Weight* ² lbs	Cable Length ft
SQ	50SQ2.4S	2	1/2	Single	Capacitor Run	0.236	7 1/16 x 14 5/16	29	32
	50SQ2.75	2	1	Three	D.O.L.	0.236	7 1/16 x 15 1/8	31	32
SFQ	50SFQ2.75	2	1	Three	D.O.L.	0.236	9 15/16 x 15 11/16	49	32
	80SFQ21.5	3	2	Three	D.O.L.	0.236	12 5/16 x 19 1/16	79	32
	80SFQ23.7	3	5	Three	D.O.L.* ¹	0.591	14 1/8 x 21 5/16	115	32
	100SFQ25.5	4	7.5	Three	D.O.L.* ¹	0.787	25 3/8 x 33 1/4	278	32
	100SFQ27.5	4	10	Three	D.O.L.* ¹	0.787	25 3/8 x 33 1/4	276	32
	100SFQ211	4	15	Three	Star-Delta	0.906	25 3/8 x 35 1/8	320	32

*¹ Star-Delta available upon request

*² Weights excluding cable

- Automatic model is available in single-phase.
- Guide rail fitting model is available in 7.5HP and above.
- As an option, the 80SFQ21.5 / 23.7 models are available for high temperature liquids of up to 176°F.

Performance Curves

< SQ Series >

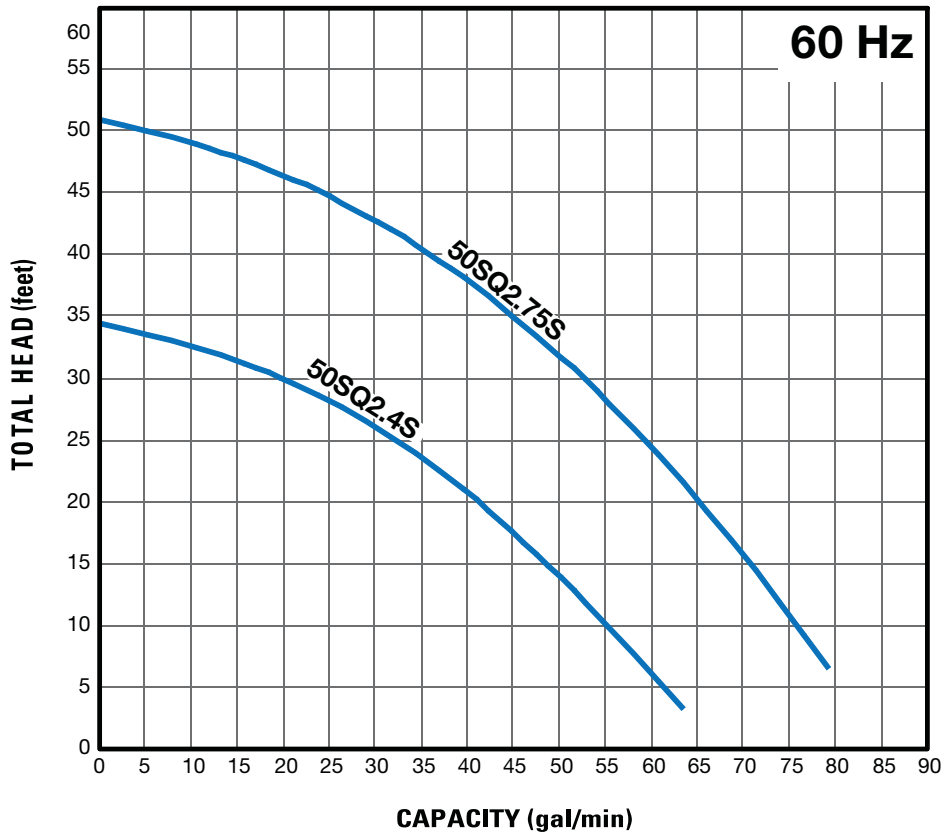

< SFQ Series >

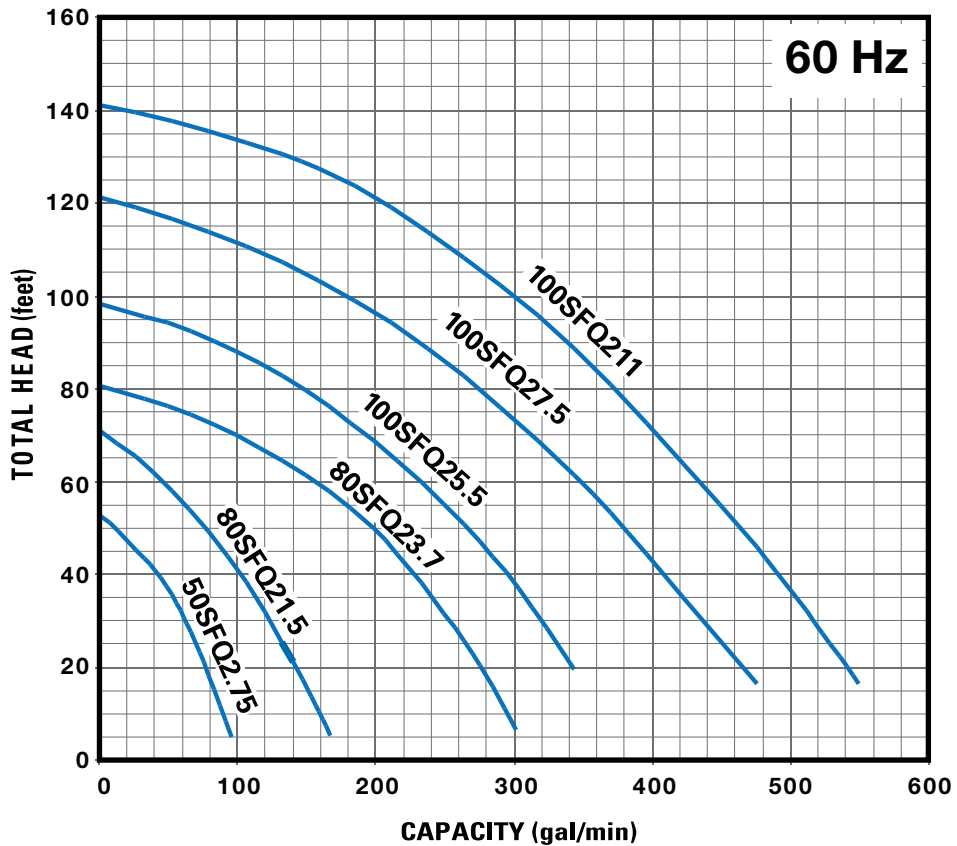

The TM-series is a submersible titanium pump designed for handling seawater. It is made of resin and titanium. Since titanium has a superb corrosion resistance against seawater, it is suitable for various applications where seawater is used. Liquid paraffin is used for the lubricating oil, which makes it ideal for saltwater aquaculture.

**50TM2.4S****50TM21.5****80TM23.7**

Model		Discharge Bore inch	Motor Output HP	Phase	Starting Method	Solids Passage inch	Dimensions Dia x Height inch	Dry Weight* lbs	Cable Length ft
TM	50TM2.25S	2	1/3	Single	Capacitor Run	0.394	9 15/16 x 14 3/16	14.8	32
	50TM2.25	2	1/3	Three	D.O.L.	0.394	9 15/16 x 13 3/4	12.6	32
	50TM2.4S	2	1/2	Single	Capacitor Run	0.394	9 5/16 x 14 3/16	14.8	32
	50TM2.4	2	1/2	Three	D.O.L.	0.394	9 5/16 x 14 3/16	14.5	32
	50TM2.75S	2	1	Single	Capacitor Run	0.394	9 5/16 x 14 15/16	18.5	32
	50TM2.75	2	1	Three	D.O.L.	0.394	9 5/16 x 14 3/4	17.2	32
	50TM21.5	2	2	Three	D.O.L.	0.787	11 5/8 x 17 1/8	32.8	32
	80TM22.2	3	3	Three	D.O.L.	0.787	8 3/8 x 22	46.3	32
	80TM23.7	3	5	Three	D.O.L.	0.787	8 3/8 x 22 3/8	57.3	32

* Weights excluding cable

• Automatic model is available.

Performance Curves

Standard and Automatic Models have the identical performance.

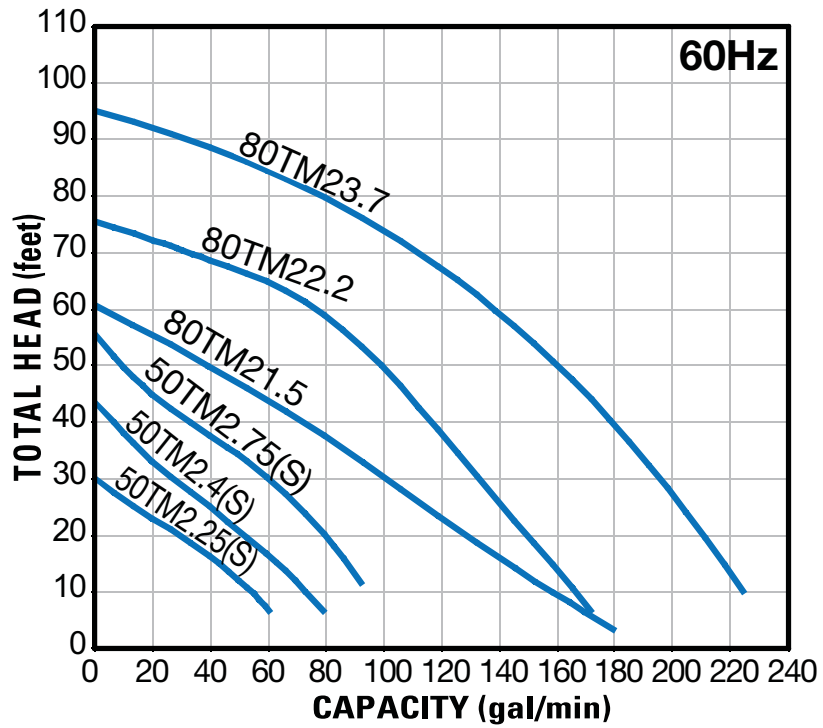

Seawater-Resistant Pumps

Tsurumi's standard pumps can be combined with a seawater-resistant kit (optional) that features a “**galvanic anode**” and “**seawater-resistant special cast iron impeller**,” for use as submersible seawater-resistant pumps. These pumps have been designed for an expected service life of about two years. (The service life depends on operating conditions.) For details, refer to the Seawater-Resistant Pumps catalog.



Specifications

		LH-14					LH-W-14		SQ			
		LH422-14	LH637-14	LH6110-14	LH837-14	LH8110-14	LH311W-14	LH322W-14	50SQ2.4S	50SQ2.75		
PUMP	Discharge Bore inch	4	6		8		3		2			
	Discharge Connection	JIS 10kg/cm ² Flange		JIS 20kg/cm ² Flange	JIS 10kg/cm ² Flange			JIS 20kg/cm ² Flange	Threaded Oval Flange			
	Solids Passage 50/60Hz inch	0.234		0.394	0.787		0.334		0.236			
	Impeller	Closed					Closed (Dual)		Vortex			
		316 Stainless Steel Casting							304 Stainless Steel Casting			
	Labyrinth Ring	316 Stainless Steel							—			
	Casing	316 Stainless Steel Casting							304 Stainless Steel Casting			
	Shaft Seal	Dual Inside Mechanical Seals (with Oil Lifter)										
		Silicon Carbide										
	Galvanic Anode	Aluminium Alloy					Zinc	Aluminium Alloy	—			
MOTOR	Type	Continuous-duty Rated, Dry-type Induction Motor										
	Output HP	30	50	150	50	150	15	30	1/2	1		
	Phase	Three							Single	Three		
	Pole	2										
	Insulation	F					B	F	E			
	Starting Method	D.O.L.	Star-Delta				D.O.L.		Capacitor Run	D.O.L.		
	Motor Protector (built-in)	MTP							MTP	CTP		
	Leakage Sensor (built-in)	—		Electrode	—		Electrode	—				
	Lubricant ml	6300* ²	4300* ²	7100* ²	4300* ²	7100* ²	2100* ²		230			
		Turbine Oil (ISO VG32)							Liquid Paraffin (ISO VG32)			
Frame	316 Stainless Steel							304 Stainless Steel				
Shaft	316 Stainless Steel							304 Stainless Steel				
Cable ft	32		65	32	65			32				
	Chloroprene Rubber							PVC				
Dry Weight* ¹ lbs	815* ²	1190* ²	2980* ²	1190* ²	3090* ²	705* ²	750* ²	29	31			

*¹ Weights excluding cable

*² Approximate value

SFQ						TM						
50SFQ2.75	80SFQ21.5	80SFQ23.7	100SFQ25.5	100SFQ27.5	100SFQ211	50TM2.25S 50TM2.25	50TM2.4S 50TM2.4	50TM2.75S 50TM2.75	50TM21.5	80TM22.2	80TM23.7	
2	3		4			2			3			
Threaded Oval Flange			Threaded JIS 10kg/cm ² Flange			Threaded Oval Flange						
0.236		0.591	0.787	0.906		0.394			0.787			
Semi-open						Vortex						
316 Stainless Steel Casting						Glass-fiber Reinforced PPO				Glass-fiber Reinforced PA+ABS		
—												
316 Stainless Steel Casting						Glass-fiber Reinforced ABS			Glass-fiber Reinforced PA+ABS			
Dual Inside Mechanical Seals (with Oil Lifter)												
Silicon Carbide												
—												
Continuous-duty Rated, Dry-type Induction Motor												
1	2	5	7.5	10	15	1/3	1/2	1	2	3	5	
Three						Single ----- Three			Three			
2												
E	F					E						
D.O.L.				Star-Delta	Capacitor Run ----- D.O.L.			D.O.L.				
CTP				MTP	MTP ----- CTP			CTP				
—												
125	900	850	2250			240			500	680		
Turbine Oil (ISO VG32)						Liquid Paraffin (ISO VG32)						
316 Stainless Steel Casting						Titanium						
316 Stainless Steel						Titanium						
32						32 ----- 32			32			
PVC			Chloroprene Rubber			PVC						
49	79	115	278	276	320	14.8 ----- 12.6		18.5 ----- 17.2		32.8	46.3	57.3

We reserve the right to change the specifications and designs for improvement without prior notice.



1625 Fullerton Court, Glendale Heights, IL 60139
Tel: 1-888-878-7864 • Fax: 1-630-793-0146
www.tsurumipump.com • info@tsurumiamerica.com

Your Dealer