



TSURUMI PORTABLE GENERATOR

*FOR TSURUMI TPG-SERIES
PORTABLE GENERATORS*

INSTRUCTION MANUAL

MODELS: TPG4-3000HDX
TPG4-3400HDX
TPG4-4500HDX
TPG4-6000HDX
TPG4-7000HDX
TPG4-7000HDXE
TPG4-7500HDX
TPG4-7500HDXE



TSURUMI PORTABLE GENERATOR

1625 FULLERTON COURT GLENDALE HEIGHTS ILLINOIS 60139 U.S.A.

PARTS NO. : 15750356000

TSURUMI A.C. GENERATORS

We thank you for purchasing a Tsurumi generator.

This manual covers operation and maintenance of the **Tsurumi generators**. All information in this publication is based on the latest production information available at the time of approval for printing.

Tsurumi reserves the right to make changes at any time without notices and without incurring any obligation.

Pay special attention to statements preceded by the following words:

⚠ WARNING

Indicates a strong possibility of severe personal injury, loss of life and equipment damage if instructions are not followed.

CAUTION

Indicates a possibility of equipment damage if instructions are not followed.

NOTE:

Gives you helpful information.

If a problem should arise, or if you have any questions about the generator, consult an authorized dealer.









⚠ WARNING

- **The generator is designed to give safe and dependable service if operated according to instructions.**
- **Do not operate the generator before you have read and understood the instructions and owner's manual of engine manufacturer.**
Failure to do so could result in personal injury or equipment damage.

CONTENTS

	Page
1. SAFETY PRECAUTIONS	1
2. SPECIFICATIONS	4
3. CONSTRUCTION.....	5
4. PRE-OPERATION CHECK.....	8
5. CHECKING COMPONENTS.....	11
6. STARTING & OPERATING THE ENGINE	12
7. GENERATOR USE.....	14
8. WATTAGE INFORMATION.....	24
9. MAINTENANCE.....	26
10. “HOW-TO” MAINTENANCE	28
11. PREPARATION FOR STORAGE.....	30
12. TROUBLE SHOOTING.....	31
13. WIRING DIAGRAM.....	34
 APPENDIX A	
BATTERY ENCLOSURE KIT ASSEMBLY AND INSTALLATION INSTRUCTIONS	

1. SAFETY PRECAUTIONS

	 WARNING
<ul style="list-style-type: none">• Do not operate the generator near gasoline or gaseous fuel because of the potential danger of explosion or fire.	
<ul style="list-style-type: none">• Do not fill the fuel tank with fuel while the engine is running. Do not smoke or use open flame near the fuel tank. Be careful not to spill fuel during refueling. If fuel is spilt, wipe it off and let dry before starting engine.	
	 WARNING
<ul style="list-style-type: none">• Do not place inflammables near the generator.	
<ul style="list-style-type: none">• Be careful not to place fuel, matches, gunpowder, oily cloths, straw, trash, or any other inflammables near the generator.	
	 WARNING
<ul style="list-style-type: none">• Do not operate the generator inside a room, cave, tunnel, or other insufficiently ventilated area.	
<ul style="list-style-type: none">• Always operate it in a well-ventilated area, otherwise the engine may become overheated, and the poisonous carbon monoxide gas contained in the exhaust will endanger human lives.	
	 WARNING
<ul style="list-style-type: none">• Keep the generator at 1 meter (3 feet) away from any structure or building during use.• Do not enclose the generator nor cover it with a box.	
<ul style="list-style-type: none">• When a generator is located close to a building or nearby equipment, heat and exhaust from the engine will cause the surrounding temperature to rise. This will worsen the engine's cooling effect, causing overheating.• The generator has a built-in forced air cooling system, and may become overheated if it is enclosed.	



WARNING

- **Operate the generator on a level surface.**

- It is not necessary to prepare a special foundation for the generator. However, the generator will vibrate on an irregular surface, so choose a level place without surface irregularities.
- If the generator is tilted or moved during operation, fuel may spill and/or the generator may tip over, causing a hazardous situation.
- Proper lubrication cannot be expected if the generator is operated on steep incline or slope. In such a case, piston seizure may occur even if the oil is above the upper level.



WARNING

- **Pay attention to the wiring from the generator the connected device.**

- If the wire is under the generator or in contact with a vibrating part, it may break and possibly cause a fire or generator burnout.



WARNING

- **Do not operate in rain or with wet hands.**

- The operator may suffer severe electric shock if the generator is wet due to rain or snow.
- If wet, wipe and dry it well before starting.
- Do not pour water directly over the generator, nor wash it with water.



WARNING

- **Do not contact the generator to a commercial power line.**

- Connection to a commercial power line may short circuit the generator and ruin it. Use the transfer switch for connecting to domestic circuits.



WARNING

- **No smoking while handling the battery.**

- The battery emits flammable hydrogen gas, which can exploded if exposed to electric arcing or open flame.
- Keep the area well-ventilated and keep open flames/sparks away when handling the battery.

SAFETY LABEL LOCATION

These labels warn you of potential hazards that can cause serious injury.



Read them carefully.

If a label comes off or becomes hard to read, contact your Tsurumi dealer for a replacement.

 **AUTOMATIC SHUTOFF - YOU MUST:**

MOVE GENERATOR TO AN OPEN, OUTDOOR AREA. POINT EXHAUST AWAY. DONT RUN GENERATOR IN ENCLOSED AREAS (E. G. NOT IN HOUSE OR GARAGE).



  **MOVE TO FRESH AIR AND GET MEDICAL HELP IF SICK, DIZZY OR WEAK.**



⚠ DANGER

Using a generator indoors CAN KILL YOU IN MINUTES.

Generator exhaust contains carbon monoxide. This is a poison you cannot see or smell.

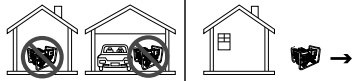

NEVER use inside a home or garage, EVEN IF doors and windows are open.

Only use OUTSIDE and far away from windows, doors, and vents.

<p>⚠ WARNING</p>	<p>DO NOT USE INDOORS. EXHAUST GAS CONTAINS POISONOUS CARBON MONOXIDE.</p>	<p>⚠ WARNING</p>	<p>USING THE GENERATOR IN RAIN, SNOW OR NEAR WATER CAN LEAD TO DEATH FROM ELECTRIC SHOCK. KEEP GENERATOR DRY.</p>
<p>⚠ ATTENTION</p>	<p>NE PAS UTILISER DANS UN ENDOIT FERMÉ À CAUSE DU RISQUE D'EMPOISONNEMENT DU GAZ.</p>	<p>⚠ WARNING</p>	<p>ELECTROCUTION OR PROPERTY DAMAGE CAN OCCUR. DO NOT CONNECT THIS GENERATOR TO ANY BUILDING'S ELECTRICAL SYSTEM UNLESS AN ISOLATOR SWITCH HAS BEEN INSTALLED BY A LICENSED ELECTRICIAN. READ OWNER'S MANUAL CAREFULLY.</p>
<p>⚠ ATENCION</p>	<p>NO LO USE EN LUGARES CERRADOS PORQUE EL MONOXIDO DE CARBONO ES VENENOSO.</p>	<p>⚠ CAUTION</p>	<p>EXCEEDING GENERATORS WATTAGE/AMPERAGE CAPACITY CAN DAMAGE GENERATOR AND/OR ELECTRICAL DEVICES CONNECTED TO IT.</p> <ul style="list-style-type: none"> • START GENERATOR AND LET ENGINE STABILIZE BEFORE CONNECTING ELECTRICAL LOADS. • NO SENSITIVE EQUIPMENT LIKE COMPUTERS, STEREOS, TVS, ETC.

3. CONSTRUCTION

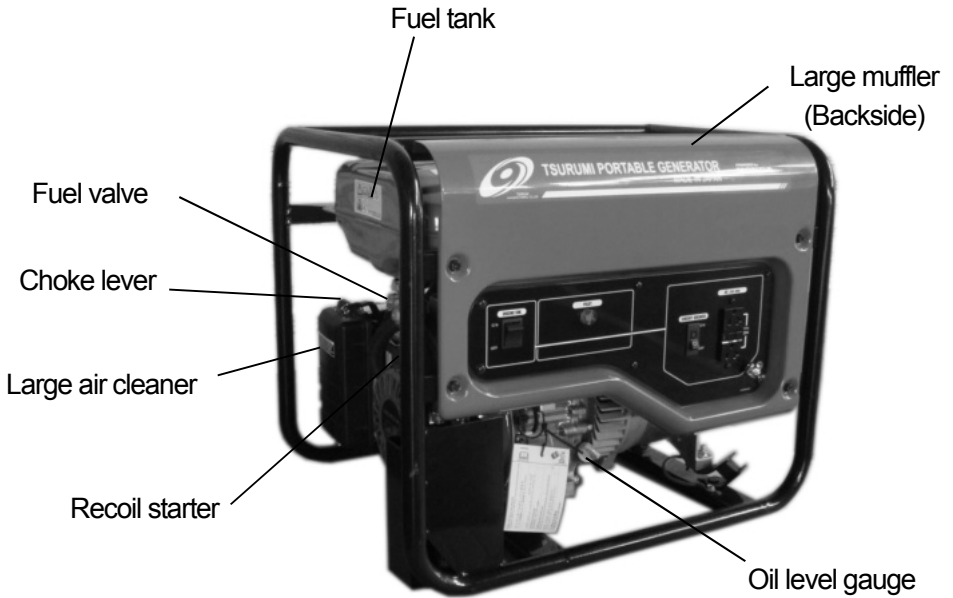

TPG4-3000HDX

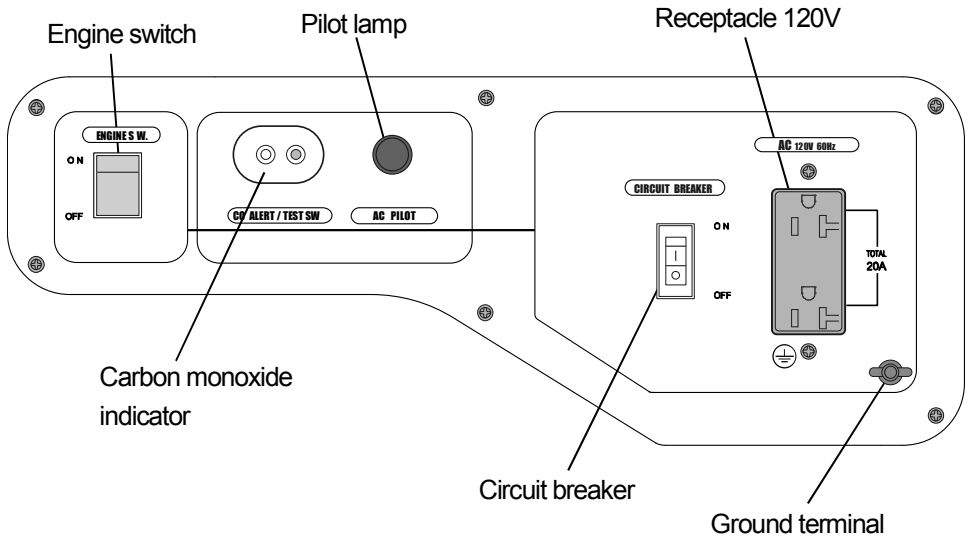

TPG4-3400HDX

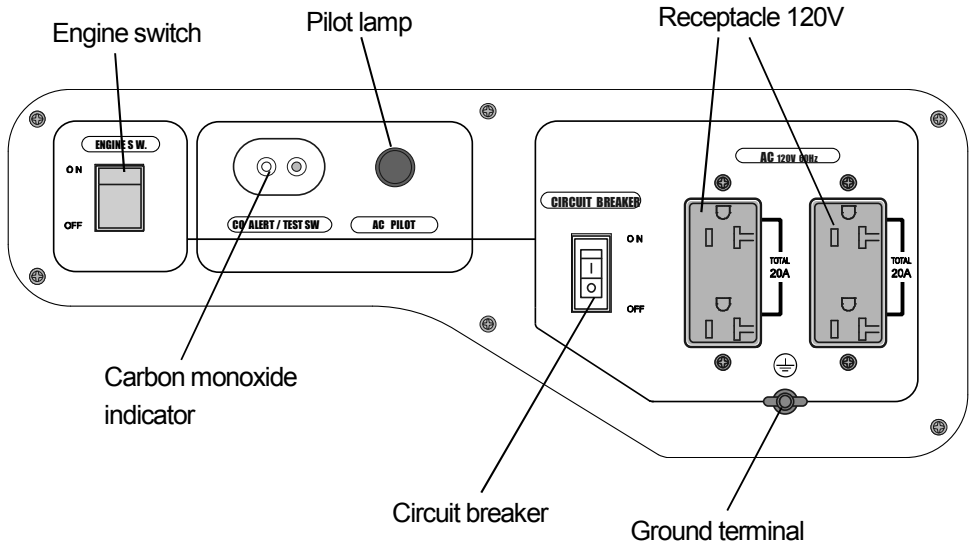

TPG4-4500~7500HDX

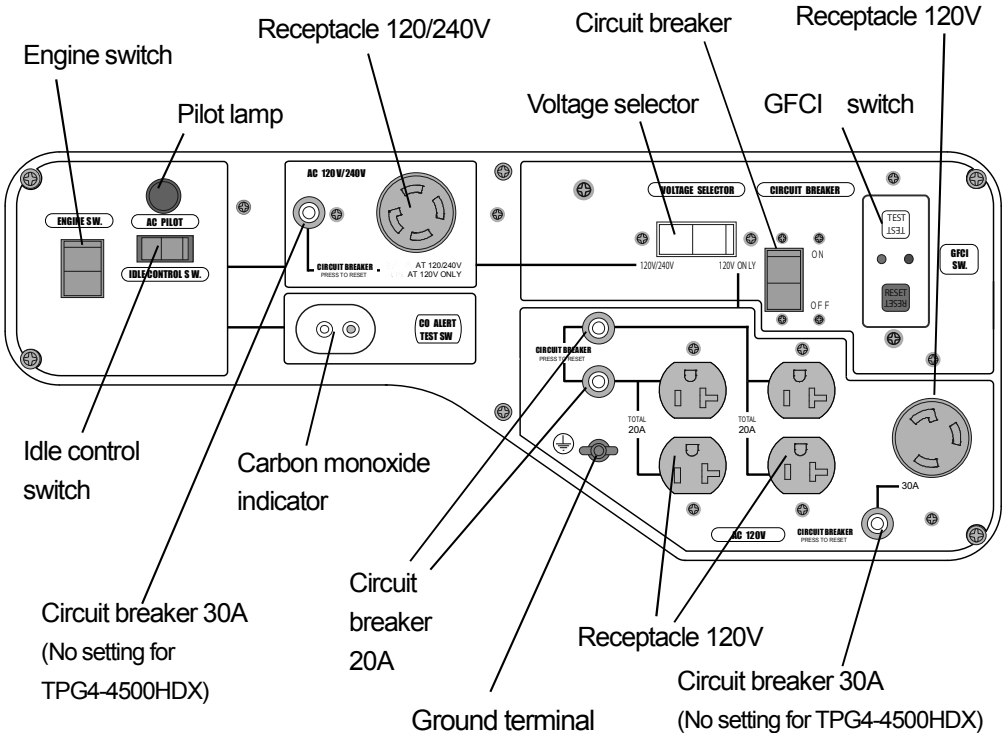

TPG4-7000~7500HDXE

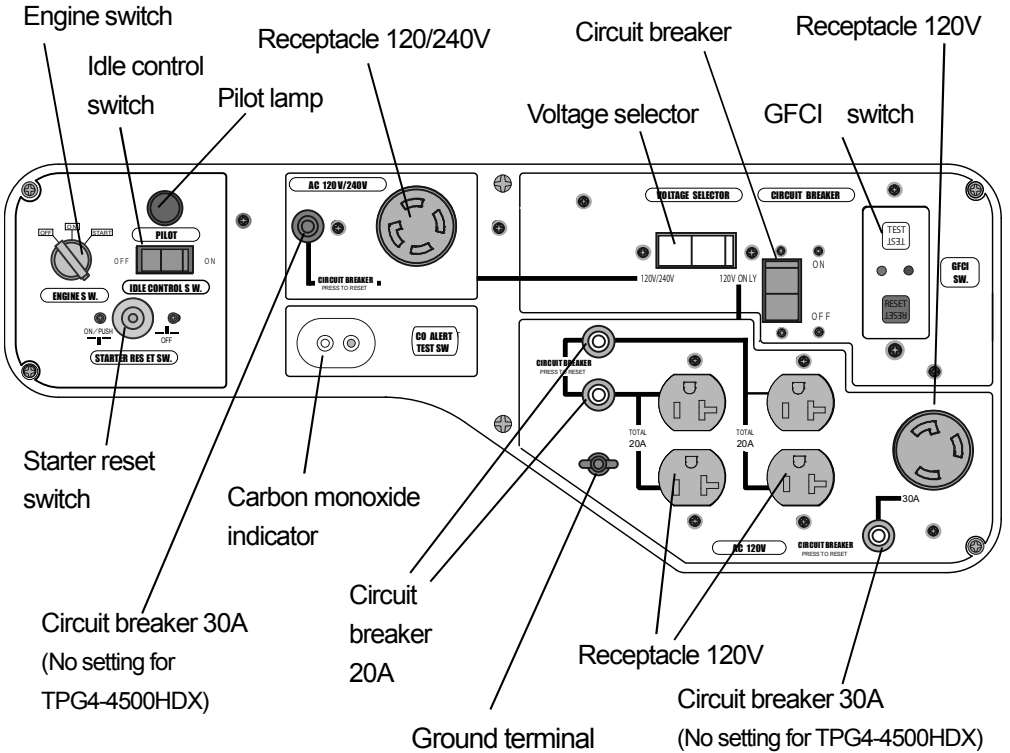

4. PRE-OPERATION CHECK

CHECK THE ENGINE OIL LEVEL

Check the engine oil level with the engine stopped and in a level position.

CAUTION

- Engine oil is a major factor affecting performance and service life. Non-detergent oils and 2-stroke oils are not recommended because they have inadequate lubricating characteristics.
- Check the oil level with the engine on a level surface and the engine stopped.
- Running the engine with a low oil level can cause engine damage.

1. Remove the filler cap/dipstick and wipe it clean.
2. Insert and remove the dipstick without screwing it into the filler neck. Check the oil level shown on the dipstick.
3. If the oil level is low, fill to the edge of the oil filler hole with the recommended oil.
4. Screw in the filler cap/dipstick securely.

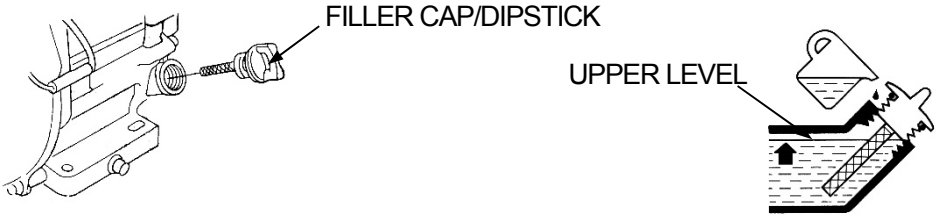

ENGINE OIL RECOMMENDATIONS

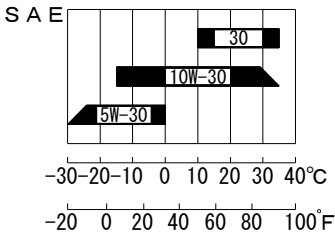

AMBIENT TEMPERATURE

Oil is a major factor affecting performance and service life. Use 4-stroke automotive detergent oil.

SAE 10W-30 is recommended for general use. Other viscosities shown in the chart may be used when the average temperature in your area is within the recommended range.

Maker recommends that you use API SERVICE category SF or SG oil.

CHECK ENGINE FUEL

⚠ WARNING

- **Do not refuel while smoking or near open flame or other such potential fire hazards. Otherwise fire accident may occur.**
Make sure you review each warning in order to prevent fire hazard.
 - **Do not refill tank while engine is running or hot.**
 - **Close fuel cock before refueling with fuel.**
 - **Be careful not to admit dust, dirt, water or other foreign objects into fuel.**
 - **Wipe off spilt fuel thoroughly before starting engine.**
 - **Keep open flames away.**
- Avoid repeated or prolonged contact with skin or breathing of vapor. Keep out of reach of children.
 - Check fuel level at fuel level gauge.
 - If fuel level is low, refill with unleaded automotive gasoline.
- **Fuel tank capacity.**
 - TPG4-3000HDX ...4.2 gal
 - TPG4-3400HDX ...4.2 gal
 - TPG4-4500HDX ...6.6 gal
 - TPG4-6000HDX ...6.6 gal
 - TPG4-7000HDX ...6.6 gal
 - TPG4-7000HDXE ...6.6 gal
 - TPG4-7500HDX ...6.6 gal
 - TPG4-7500HDXE ...6.6 gal

FUEL GAUGE

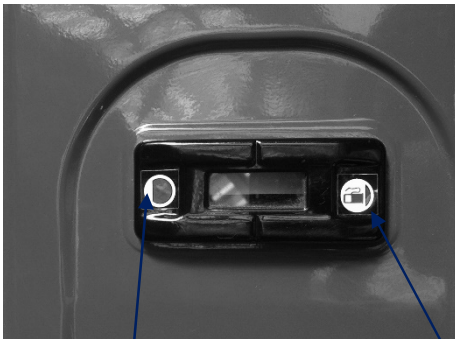

FULL

EMPTY

Oxygenated Fuels

Some conventional gasolines are being blended with alcohol or an ether compound. These gasolines are collectively referred to as oxygenated fuels.

To meet clean air standards, some areas of the United States and Canada use oxygenated fuels to help reducing emissions.

If you use an oxygenated fuel, be sure it is unleaded and meets the minimum octane rating requirement.

Before using an oxygenated fuel, try to confirm the fuel's contents.

Some states/provinces require this information to be posted on the generator.

The following are the EPA approved percentages of oxygenates:

ETHANOL.....(ethyl or grain alcohol) 10% by volume

You may use gasoline containing up to 10% ethanol by volume.

Gasoline containing ethanol may be marketed under the name "Gasohol".

MTBE(methyl tertiary butyl ether) 15% by volume

You may use gasoline containing up to 15% MTBE by volume.

METHANOL.....(methyl or wood alcohol) 5% by volume

You may use gasoline containing up to 5% methanol by volume as long as it also contains solvents and corrosion inhibitors to protect the fuel system.

Gasoline containing more than 5% methanol by volume may cause starting and/or performance problems. It may also damage metal, rubber, and plastic parts of your fuel system.

If you notice any undesirable operating symptoms, try another service station or switch to another brand of gasoline.

Fuel system damage or performance problems resulting from the use of an oxygenated fuel containing more than the percentages of oxygenates mentioned above are not covered under warranty.

5. CHECKING COMPONENTS

Check following items before starting engine:

- Fuel leakage from fuel hose, etc.
- Bolts and nuts for looseness.
- Components for damage or breakage.

CHECK GENERATOR SURROUNDINGS

WARNING

Make sure you review each warning in order to prevent fire hazard.

- **Keep area clear of inflammables or other hazardous materials.**
- **Keep generator at least 3 feet (1 meter) away from buildings or other structures.**
- **Only operate generator in a dry, well-ventilated area.**
- **Keep exhaust pipe clear of foreign objects.**
- **Keep generator away from open flame.**
- **Keep generator on a stable and level surface.**
- **Do not block generator air vents with paper or other material.**

6. STARTING & OPERATING THE ENGINE

- Before starting the engine, turn off the A.C. circuit breaker.
 - Please, refer to the owner's manual of engine manufacturer.
1. Turn the fuel valve on the "ON" position.

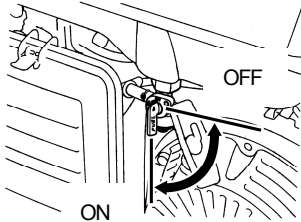

2. Move the choke lever to the "CLOSE" position.

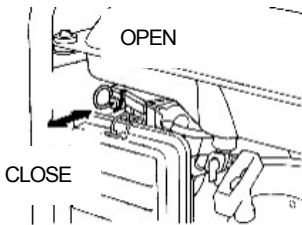

NOTE:

The choke may not be needed if the engine is warm or the air temperature is high.

3. Engine switch to the "ON" position.

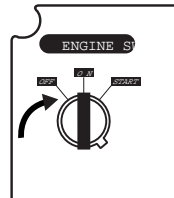
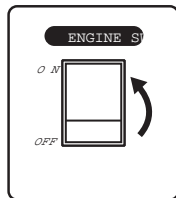

4. Operate the starter.

RECOIL STARTER

Pull the starter grip lightly until you feel resistance, then pull briskly. Return the starter grip gently.

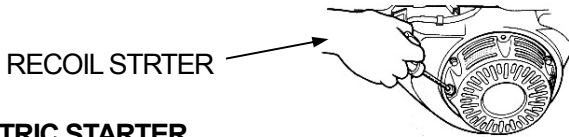

ELECTRIC STARTER

Turn the key to the “START” position, and hold it there until the engine starts. If the engine fails to start within 5 seconds, release the key, and wait at least 10 seconds before operating the starter again.

NOTE:

Using the electric starter for more than 5 seconds at a time will overheat the starter motor and can damage it.

When the engine starts, release the key, allowing it to return to the “ON” position. (TPG4-7000HDXE and TPG4-7500HDXE)

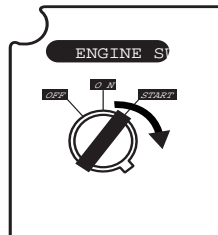

NOTE :

The model TPG4-7000HDXE and TPG4-7500HDXE generator has a 12-volt DC starting system.

Use a 12-volt, garden tractor-type battery as a replacement battery.

5. If the choke lever has been moved to the “CLOSED” position to start the engine, gradually move it to the “OPEN” position as the engine warms up.

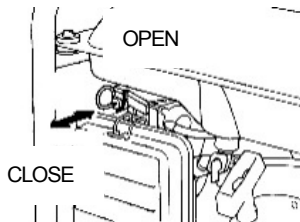

7. GENERATOR USE

⚠ WARNING

- To prevent electrical shock from faulty appliance, the generator should be grounded. Connect a length of heavy wire between the generator's ground terminal and external ground source.
- Connections for standby power to a building's electrical system must be made by a qualified electrician and must comply with all applicable laws and electrical codes. Improper connections can allow electrical current from the generator to back feed into the utility lines. Such back feed may electrocute utility company workers or others who contact the line during a power outage, and when utility power is restored, the generator may explode, burn, or cause fire the building's system.

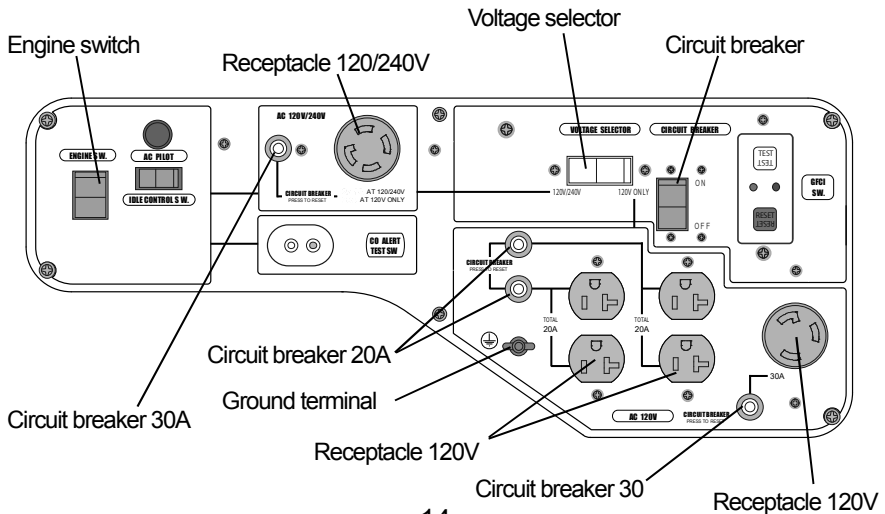
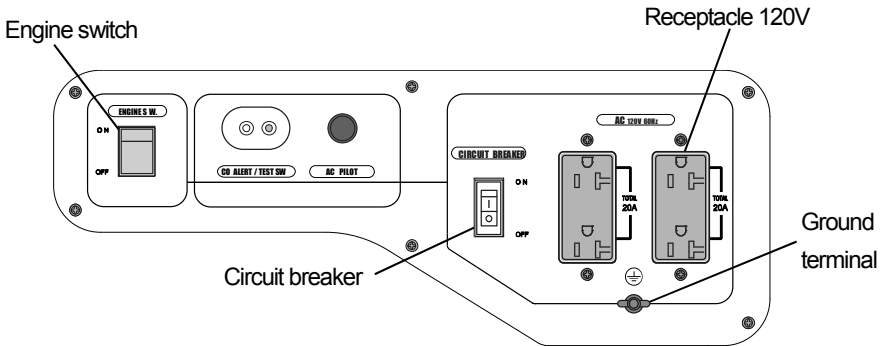





TABLE 1

Style	Ampere	Receptacle	AC plug	Description
	Up To 20 A	NEMA 5-20R	NEMA 5-20P	GFCI (Ground Fault Circuit Interrupter) Receptacle, duplex
	Up To 30 A	NEMA L14-30R	NEMA L14-30P	Locking Receptacle
	Up To 30 A	NEMA L5-30R	NEMA L5-30P	Locking Receptacle

AC APPLICATION

(a) Check the pilot lamp for proper voltage.

- This generator is thoroughly tested and adjusted in the factory. If the generator does not produce the specific voltage, consult your nearest **Tsurumi Generator** dealer.

(b) Select the voltage using the “VOLTAGE SELECTOR” accordance with the electrical appliance. Refer to **TABLE 2**.

With the voltage selector switch in the “120V/240V” position, you can use the 120V and 120V/240V receptacles simultaneously. If you are NOT using the 120V/240V receptacle, but require more power from the 120V twist lock receptacle, then select the “120V ONLY” position.

(c) Switch ON the A.C. main circuit breaker.

(d) Plug in the appliance.

Most motorized appliances require more than rated wattage for startup.

TABLE 2

Switch	Lower Voltage Receptacle	Higher Voltage Receptacle
120V	Rated output is available	Unavailable
120V/240V	Half of rated output is available	Rated output is available

⚠ WARNING

- To take out power from **TWIST LOCK** receptacle, insert the plug into receptacle and turn clockwise to lock it.
- Be sure to ground the generator if the connected electrical equipment is grounded.

Circuit Breaker

The circuit breaker will automatically switch OFF if there is a short circuit or a significant overload of the generator at the receptacle, or if the ground fault circuit interrupter (GFCI) detects a ground fault current.

Check the following if the circuit breaker switches OFF automatically:

When the GFCI RESET button is extended

Unplug all appliances from the receptacles and check the appliance for any defects as described in TROUBLESHOOTING

After making repairs, push the GFCI RESET button then turn the circuit breaker ON.

When the GFCI RESET button is not extended:

Check that the appliance is working properly and does not exceed the rated load capacity of the circuit before switching the circuit breaker ON again.

The circuit breaker may be used to switch the generator power on or off.

Ground Fault Circuit Interrupter (GFCI)

⚠ WARNING

**Using the generator in rain, snow or near water can lead to death from electric shock.
Keep the generator dry.**

All receptacles on the generator are protected by a ground fault circuit interrupter (GFCI) for protection against the shock hazard of ground fault current. The GFCI has TEST and RESET buttons and is connected to the circuit breaker.

An example of ground fault current is the current which would flow through a person who is using an appliance with faulty insulation and, at the same time, is in contact with an electrical ground such as a plumbing fixture, wet floor, or earth.

The ground fault circuit interrupter will not protect against short circuits or overloads. The circuit breaker in the control panel which supplies power to the circuit provides that protection (refer to circuit breaker).

Observe the following precautions to ensure proper GFCI operation and to reduce shock hazards:

- Use grounded 3-conductor extension cords, tools, and appliances, or double-insulated tools and appliances.
- Inspect cords and plugs, and replace if damaged.
- Do not use cord lengths greater than 164 feet (50 meters), and do not use multiple tools and appliances with built-in noise filters. Such use may activate the GFCI and trip the circuit breaker.

Inspection:

Always check GFCI operation before using the generator.

⚠ WARNING

You risk electric shock if you operate this generator with a faulty GFCI (ground fault circuit interrupter).

Test GFCI before use.

If the GFCI fails testing, do not use your generator. Contact your TSURUMI dealer.

1. Unplug all tools and appliances from the generator.
2. Start the engine.
3. Turn the circuit breaker to the ON position.
The GFCI green LED lamp lights up.
4. Turn the Idle Control switch to the OFF position.
5. Press the GFCI TEST button.
Circuit breaker to be automatically OFF position.
The GFCI red LED lamp lights up.

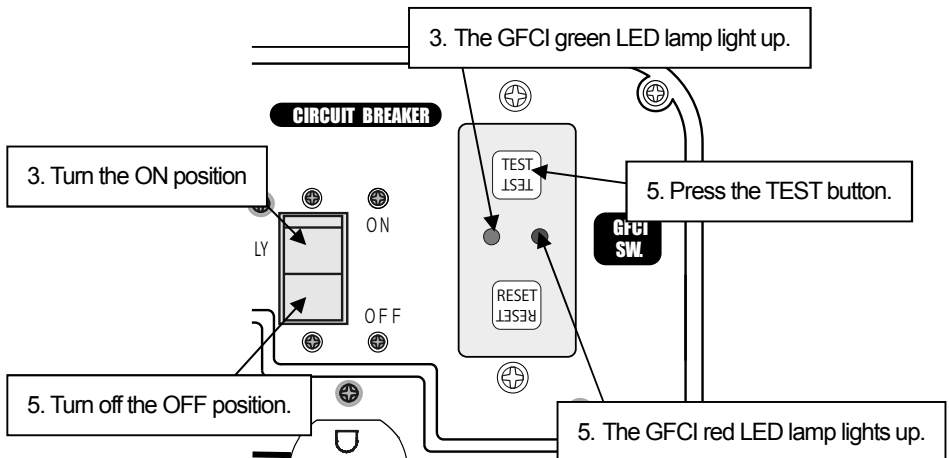

6. Press the GFCI RESET button.
The GFCI green LED lamp lights up.
7. Turn the circuit breaker ON position

With the RESET button in and engine running, turn the circuit breaker to the ON position. The circuit breaker should remain in the ON position.
The circuit breaker will not remain in the ON position if the RESET button is extended.

If the GFCI and circuit breaker do not function as described, take the generator to an authorized TSURUMI generator dealer for repair.

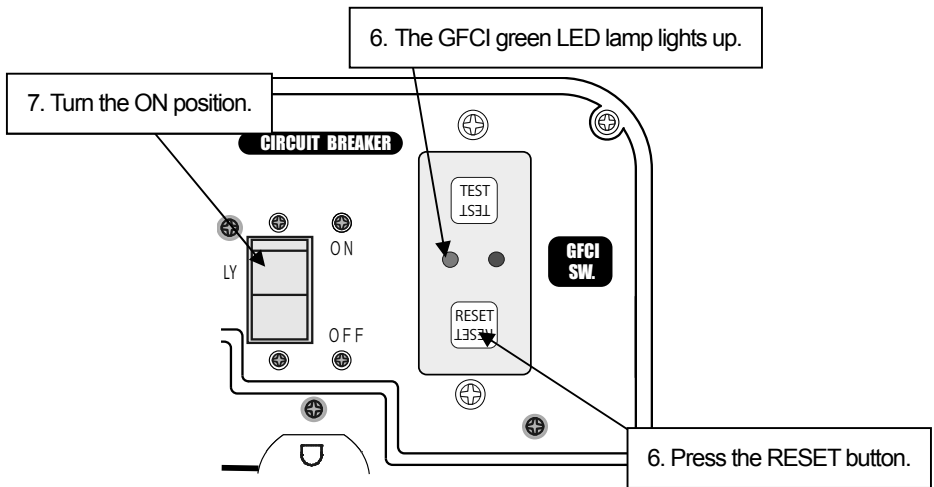

During generator use, if the GFCI RESET button extends and the circuit breaker trips, this usually indicates a faulty power tool, appliance, or cord.

If that occurs, perform test steps 1 through 6 to verify that the GFCI and circuit breaker are in proper working order. If the GFCI and circuit breaker test correctly, then you will know that the fault is in the power tool, appliance, or cord. Repair or replace the faulty power tool, appliance, or cord before further use.

NOTE:

- When the circuit breaker turns off during operation, the generator is overload or the appliance is defective.
Stop the generator immediately, check the appliance and/or generator for overloading or defect and repair as necessary.
- Check the amperage of the receptacles used referring to TABLE 1, and be sure not to take a current exceeding the specified amperage.
- Be sure that the total wattage of all appliances dose not exceed the rated output of the generator.

CAUTION

**The 120V duplex receptacle is protected by a GFCI (Ground Fault Circuit Interrupter). The GFCI shuts off the output current from the duplex. 120V receptacle when a ground fault occurs in the generator or the appliance.
All receptacle is protected by a GFCI.**

STOPPING THE GENERATOR

- (a) Turn off the power switch of the electric equipment or unplug from the cord receptacle of the generator.
- (b) Turn the engine switch to OFF position.
- (c) Turn the fuel cock to the OFF position.



CO ALERT (AUTOMATIC SHUTOFF SYSTEM)

⚠ WARNING

- Do not operate the generator inside a room, cave, tunnel, or other insufficiently ventilated area.
Also do not enclose or cover the generator with boards or a tent, even when it is outside and away from a building.
Continuously using the generator in areas with high concentrations of carbon monoxide can cause serious health hazards due to carbon monoxide poisoning.
- Always operate it in a well-ventilated area, otherwise the engine may become overheated, and the poisonous carbon monoxide gas contained in the exhaust will endanger human lives.
- Get fresh air and seek medical attention immediately if you feel sick or suspect you have inhaled carbon monoxide.

This generator is equipped with CO-ALERT.

CO ALERT is a system that automatically stops the engine before the surrounding carbon monoxide concentration exceeds a certain level.

In this operation manual, carbon monoxide is shown as CO.

● Normal Use

When the generator is operated normally, no notification.

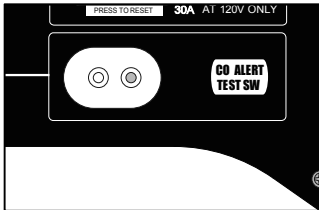

● Alert

When the generator is exposed to CO, RED light blinks with a maximum period of 2 seconds and the engine stops automatically.

The RED light will flash for up to 5 minutes after the engine stopped.

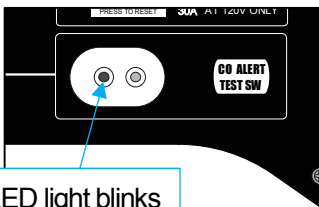

RED light blinks

● **System Fault**

When CO-ALERT has system fault, YELLOW light blinks with a maximum period of 2 seconds and the engine stops within 30 seconds.

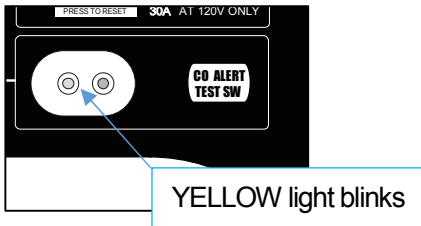

When YELLOW light blinks, contact your TSURUMI GENERATOR dealer immediately.

Test switch operation

1. Start the generator.
2. Press CO-ALERT Test switch for 1 second.

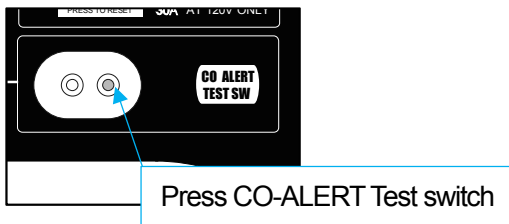

3. The engine stops.
4. The engine restarts. Both RED and YELLOW light blinks 2 times.



5. When the engine shuts off within 30 seconds, please refer trouble shooting.

OIL ALERT

- (a) The oil alert detects the fall in oil level in the crankcase and automatically stops the engine when the oil level falls down below the predetermined level.
- (b) When engine has stopped automatically, check the oil level. Refill engine oil to the upper level and restart the engine.
- (c) If the engine does not start by usual procedures, check the oil level.

IDLE CONTROL

IDLE CONTROL automatically reduces engine speed when load is OFF, and automatically increases engine speed up to rated r.p.m. when load is ON.

IDLE CONTROL provides fuel economy and low noise operation at no-load running.

HOW TO USE IDLE CONTROL

- Start the engine with IDLE CONTROL SWITCH off.

NOTE:

Warm up the engine without a load for a few minutes.

- Turn IDLE CONTROL SWITCH on.

(1) CHECKING THE OPERATION

- When IDLE CONTROL does not operate normally, please check followings.
- Overloaded.
Please make sure that generator is not overloaded.

NOTE:

Most induction loads such as electric motor require three to five times large wattage of their rating at starting.

This starting wattage should not exceed the rated output of the generator.

- Turn the IDLE CONTROL SWITCH off when the IDLE CONTROL dose not works normally under the rated output.

(2) STOPPING THE ENGINE

- Turn off the switch of load or disconnect the load.
- Turn the IDLE CONTROL SWITCH off.
- Push STOP SWITCH to stop.

NOTE:

Allow the engine about 3 minutes to cool down at no-load before stopping.

8. WATTAGE INFORMATION

Some appliances need a “surge” of energy when starting. This means that the amount of electrical power needed to start the appliance may exceed the amount needed to maintain its use. See the chart below for appliances you may use with this generator.

Electrical appliances and tools normally come with a label indicating voltage, cycles/Hz, amperage (amps) and electrical power needed to run the appliance or tool. Check with your nearest dealer with questions regarding power surge of certain appliances or power tools.

- Electrical loads such as incandescent and lamps hot plates require the same wattage to start as needed to maintain use.
- Loads such as fluorescent and mercury lamp require 1.2 to 2 times the indicated wattage to start.
- Electrical motors require a large starting current. Power requirements depend on the type of motor and its use. Once enough “surge” is attained to start the motor, the appliance will require only 50% to 30% of the wattage to continue running.

CAUTION

- **Check motor starting current and power factor carefully.**
- Most electrical tools require 1.2 to 3 times their wattage for running. For example, the 5,000 watts generated could power 1800 to 4000 watt electrical drill.
- Loads such as submersible pumps and air compressors require a very large force to start. They need 3 to 5 times the wattage needed to maintain the tool in order to start. For example, a 5,000-watt generator would only be able to drive a 1,000 to 1,700 watt pump.

NOTE:

The following wattage chart is guidance only; refer to your specific appliance for correct wattage.

To determine the total wattage required to run a particular electrical appliance or tool, multiply the total wattage figure of the appliance/tool by the amperage (amps) figure of it. The voltage and amperage (amps) information can be found on a label, which is normally attached to electrical appliances and tools.

Application	Applicable Wattage (W)			
	TPG4-3000HDX	TPG4-3400HDX	TPG4-4500HDX	TPG4-6000HDX
Incandescent lamp, heater	2200	2900	3600	4800
Fluorescent lamp, mercury lamp	1200	1400	2000	2900
Electric tool	1200	1400	2000	2900
Pump, compressor	500	600	700	1000

Application	Applicable Wattage (W)			
	TPG4-7000HDX	TPG4-7000HDXE	TPG4-7500HDX	TPG4-7500HDXE
Incandescent lamp, heater	6000	6000	6500	6500
Fluorescent lamp, mercury lamp	3700	3700	3900	3900
Electric tool	3700	3700	3900	3900
Pump, compressor	1300	1300	1400	1400

9. MAINTENANCE

The purpose of the maintenance and adjustment schedule is to keep the generator in the best operating condition.

Inspect or service as scheduled in the table below.

⚠ WARNING

- **Shut off engine before performing any maintenance. If the engine must be run, make sure the area is well ventilated. The exhaust contains poisonous carbon monoxide gas.**
- **It may cause burns while the engine is hot. Equip appropriate working gear and use caution when working with hot engines.**
- **Most used oils contain small amounts of substances that can cause cancer and other health problems. Do not inhale, ingest, or leave in contact with the skin for long periods of time.**

CAUTION

- **Please refer to the owner's manual of engine manufacturer.**

MAINTENANCE SCHEDULE

REGULAR SERVICE PERIOD		Each use	First Month or 20 Hrs. (3)	Every 3 months or 50 Hrs. (3)	Every 6 months or 100 Hrs. (3)	Every year or 300 Hrs. (3)
Performed at every indicated month or operating hour interval, whichever comes first.						
Engine oil	Check level	○				
	Change		○		○	
Air cleaner	Check	○				
	Clean			○ (1)		
Sediment cup	Clean				○(4)	
Spark plug	Clean-clean				○	
Spark arrester	Clean				○(4)	
Vale clearance	Check-Adjust					○ (2)
Fuel tank and strainer	Clean					○ (2)(4)

- (1) Service more frequently when used in dusty area.
- (2) Authorized dealer should service these items, unless the owner has the proper tools and is mechanically proficient.
- (3) For professional commercial use, long hours of operation to determine proper maintenance intervals.
- (4) In order to maintain U.S.EPA non-load emission regulation, use replacement parts.

10. "HOW-TO" MAINTENANCE

1. CHANGING ENGINE OIL

Drain the oil while the engine is still warm to assure rapid and complete draining.

1. Remove the oil filler cap and drain plug to drain the oil.
2. Install the drain plug, and tighten it securely.
3. Refill with the recommended oil, and check the oil level.
4. Install the oil filler cap.

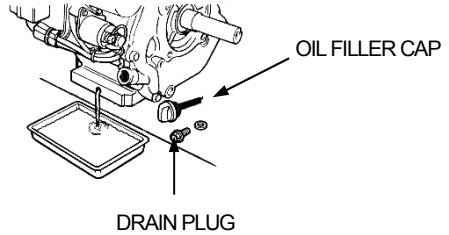

2. AIR CLEANER SERVICE

A dirty air cleaner will restrict airflow the carburetor. To prevent carburetor malfunction, service the air cleaner regularly. Service more frequently when operating the generator in extremely duty areas.

⚠️ WARNING

- **Never use gasoline or low flash point solvent for cleaning the air cleaner element. A fire or explosion could result.**

1. Unsnap the air cleaner cover clips, remove the air cleaner cover, and remove the element.
2. Wash the element in a solution of household detergent and warm water, then rinse thoroughly; or wash in nonflammable or high flash point solvent. Allow the element to dry thoroughly.
3. Soak the element in clean engine oil and squeeze out the excess oil. The engine will smoke during initial start-up if too much oil is left in the element.
4. Reinstall the air cleaner element and the cover.

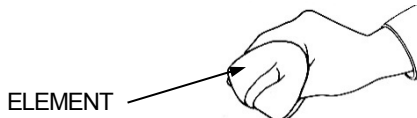
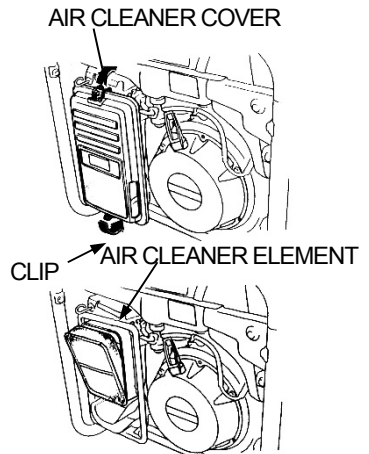

3. SEDIMENT CUP CLEANING

⚠ WARNING

- **Gasoline is extremely flammable and is explosive under certain conditions. Do not smoke or allow flames in the area.**
- **After installing the sediment cup, check for leaks, and make sure the area is free of residual fuel spills or seepage before starting the engine.**

Turn the fuel valve to “OFF” . Remove the sediment cup and O-ring, and wash them in nonflammable or flash point solvent. Dry them thoroughly, and reinstall securely.

Turn the fuel valve “ON” ,and check for leaks.

4. CLEANING AND ADJUSTING SPARK PLUG

Recommended spark plug: BPR6ES (NGK)

W20EPR-U (NIPPONDENSO)

To ensure proper engine operation, the spark plug must be properly gapped and free of deposits.

1. Remove the spark plug cap.
2. Clean any dirt from around the spark plug base.
3. Use the proper size plug wrench to remove the spark plug.
4. Visually inspect the spark plug. Discard it if the insulator is cracked or chipped.
Clean the spark plug with a wire brush if it is to be reused.
5. Measure the plug gap with a feeler gauge.
Correct as necessary by bending the side electrode.
The gap should be: 0.7-0.8 mm (0.028-0.031 in)

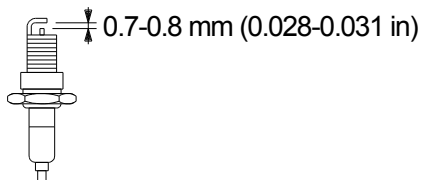

11. PREPARATION FOR STORAGE

WARNING

- To avoid severe burns or fire hazards, let the engine cool before transporting it or storing it indoors.
- When transporting the generator, turn the fuel valve to the “OFF” position and keep the engine level to prevent fuel spillage. Fuel vapor or spilled fuel may ignite.

The following procedures should be followed prior to storage of your generator for periods of 6 months or longer.

- Drain fuel from the fuel tank carefully. Gasoline left in the fuel tank will eventually deteriorate making engine-starting difficult.
- Remove the carburetor float chamber and also drain the carburetor.
- Change engine oil.
- Check for loose bolts and screws, tighten them if necessary.
- Clean generator thoroughly with oiled cloth. Spray with preservative if available. **NEVER USE WATER TO CLEAN GENERATOR!**
- Pull starter handle until resistance is felt, leaving handle in that position.
- Store generator in a well-ventilated, low humidity area.

12. TROUBLE SHOOTING

When generator engine fails to start after several attempts, or if no electricity is available at the output socket, check the following chart.

If your generator still fails to start or generate electricity, contact the nearest **TSURUMI GENERATOR** dealer for further information or corrective procedures.

When the engine will not start.

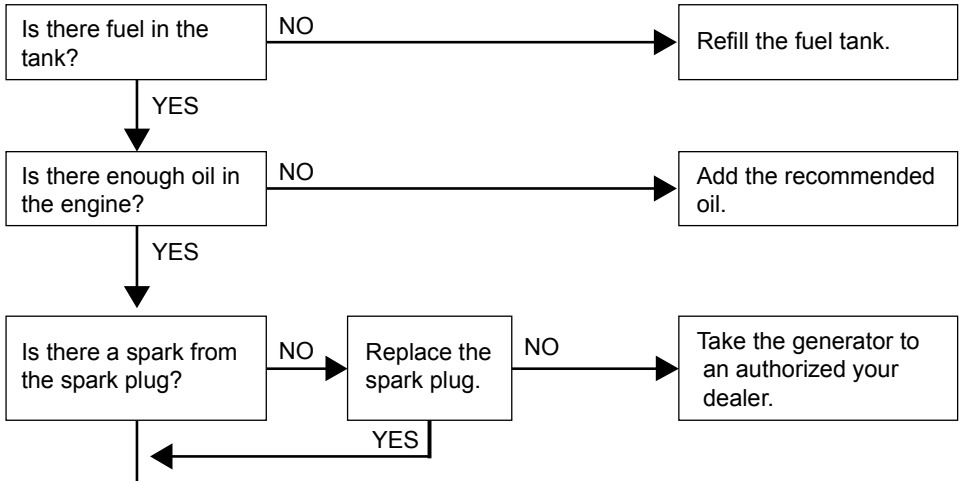

⚠ WARNING

Be sure there is no spilled fuel around the spark plug. Spilled fuel may ignite.

To check:

- Remove the spark plug cap and clean any dirt from around the spark plug.
- Remove the spark plug and install the spark plug in the plug cap.
- Set the plug side electrode on the cylinder head.
- Crank the engine, sparks should jump across the gap.

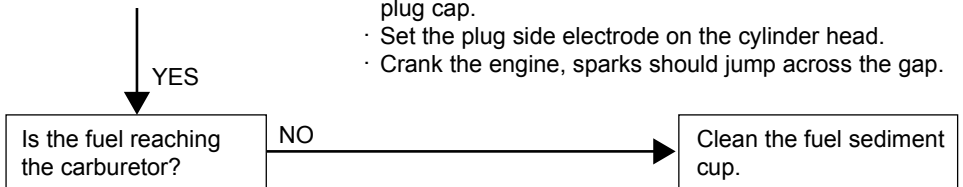

To check:

- Turn off the fuel valve and loosen the drain screw.
- Fuel should flow from the drain when the fuel valve is turned on.

No electricity at the AC receptacles;

《When the GFCI RESET button is extended》

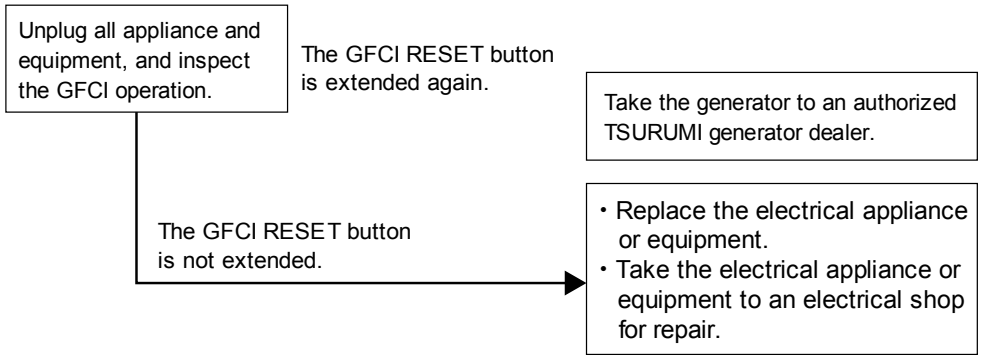

《When the GFCI RESET button is not extended》

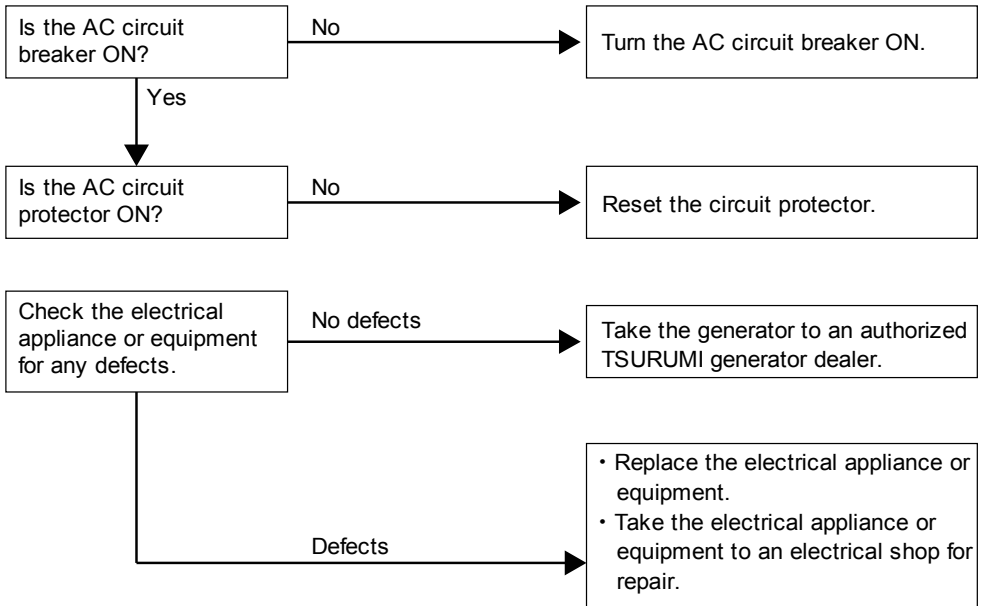

CO-ALERT System

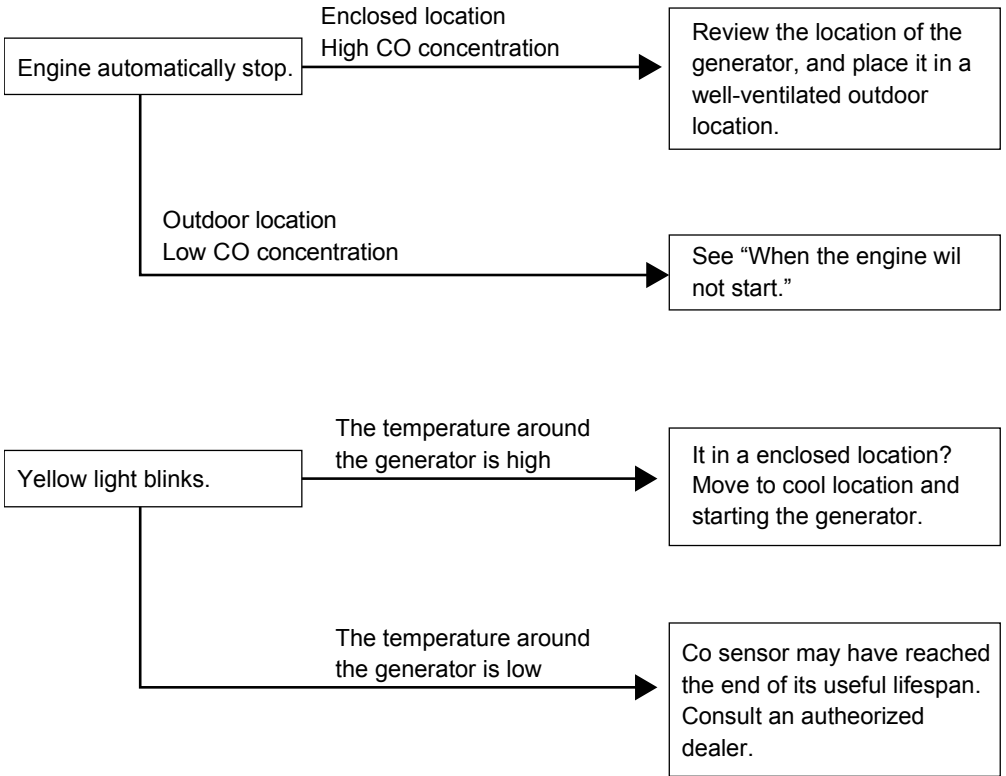

13. WIRING DIAGRAM

TPG4-3000HDX

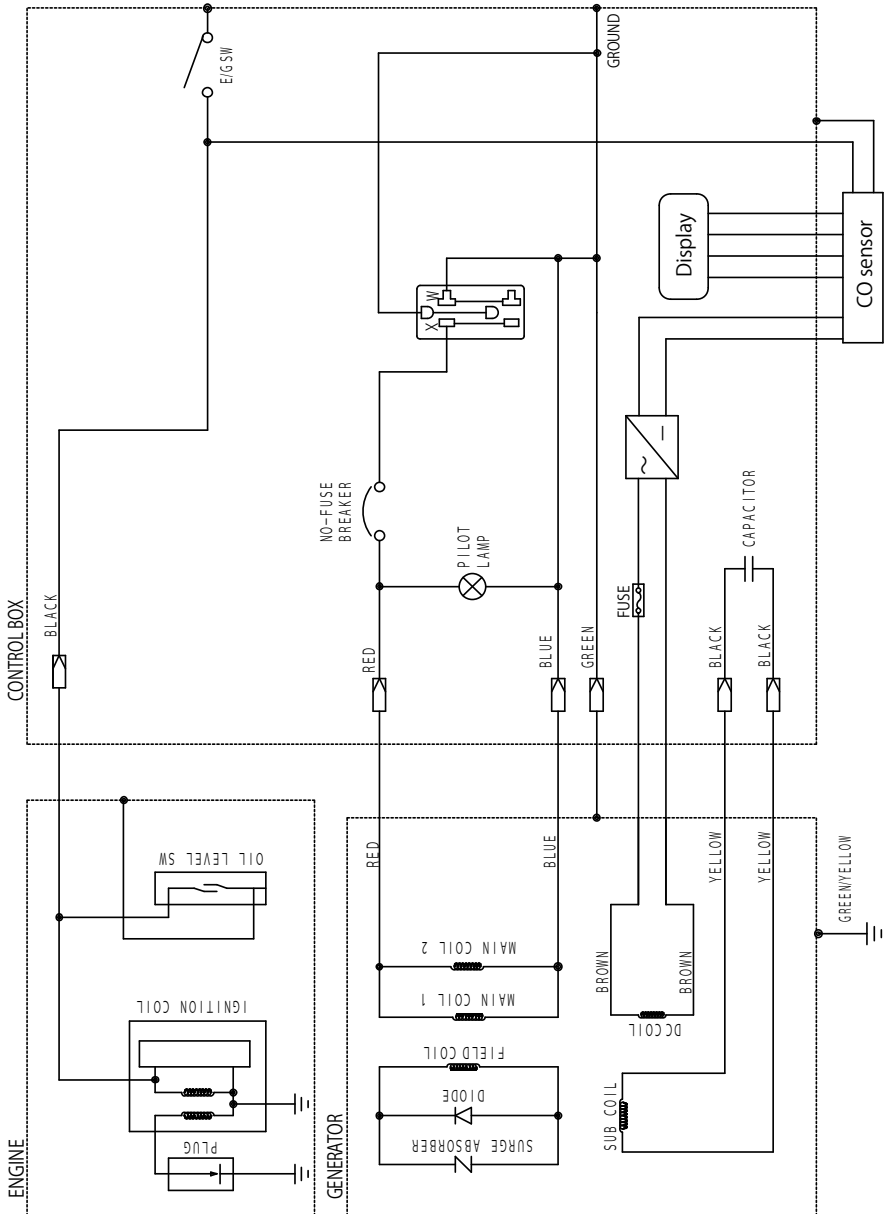

TPG4-3400HDX

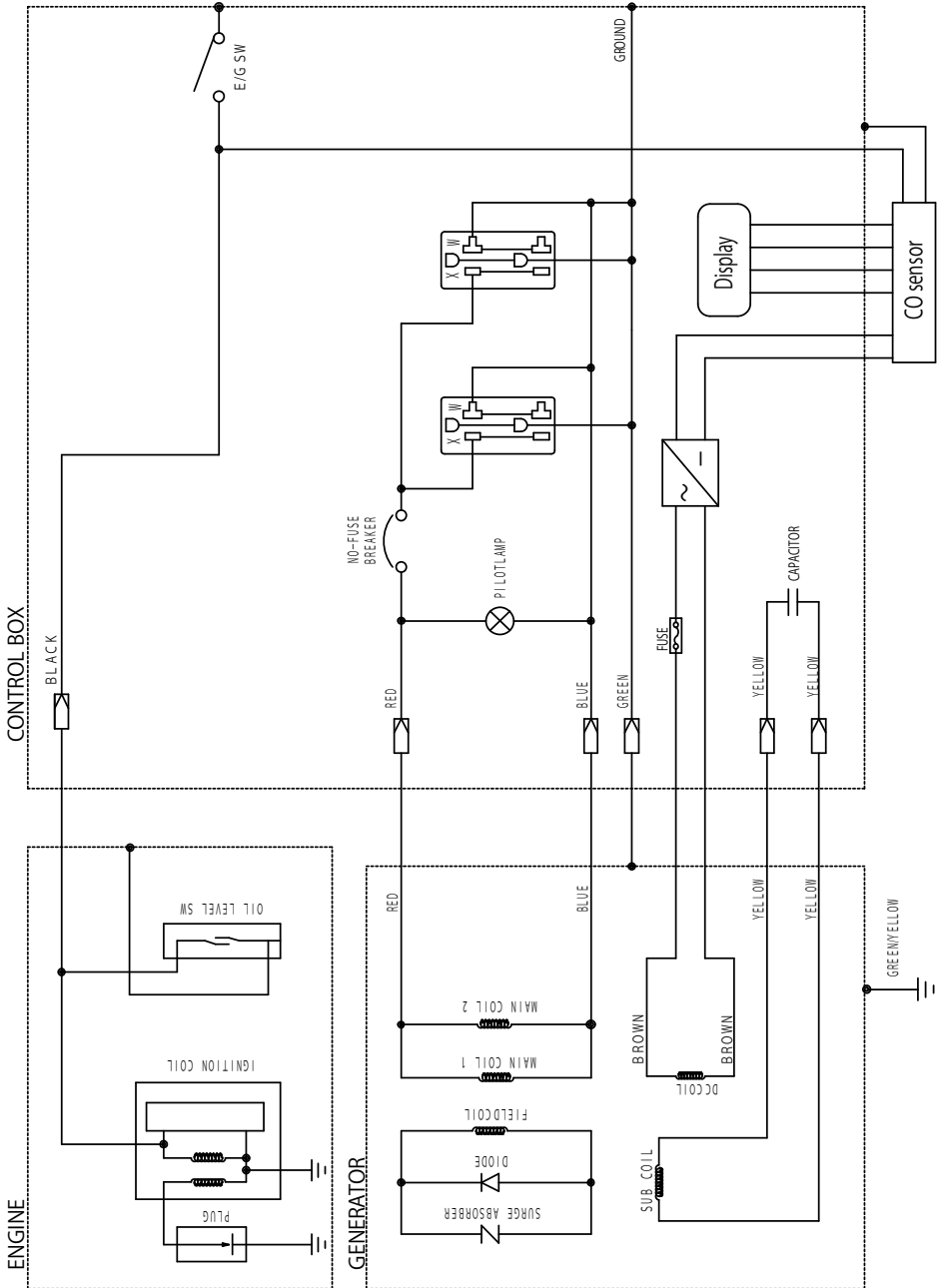

TPG4-4500HDX

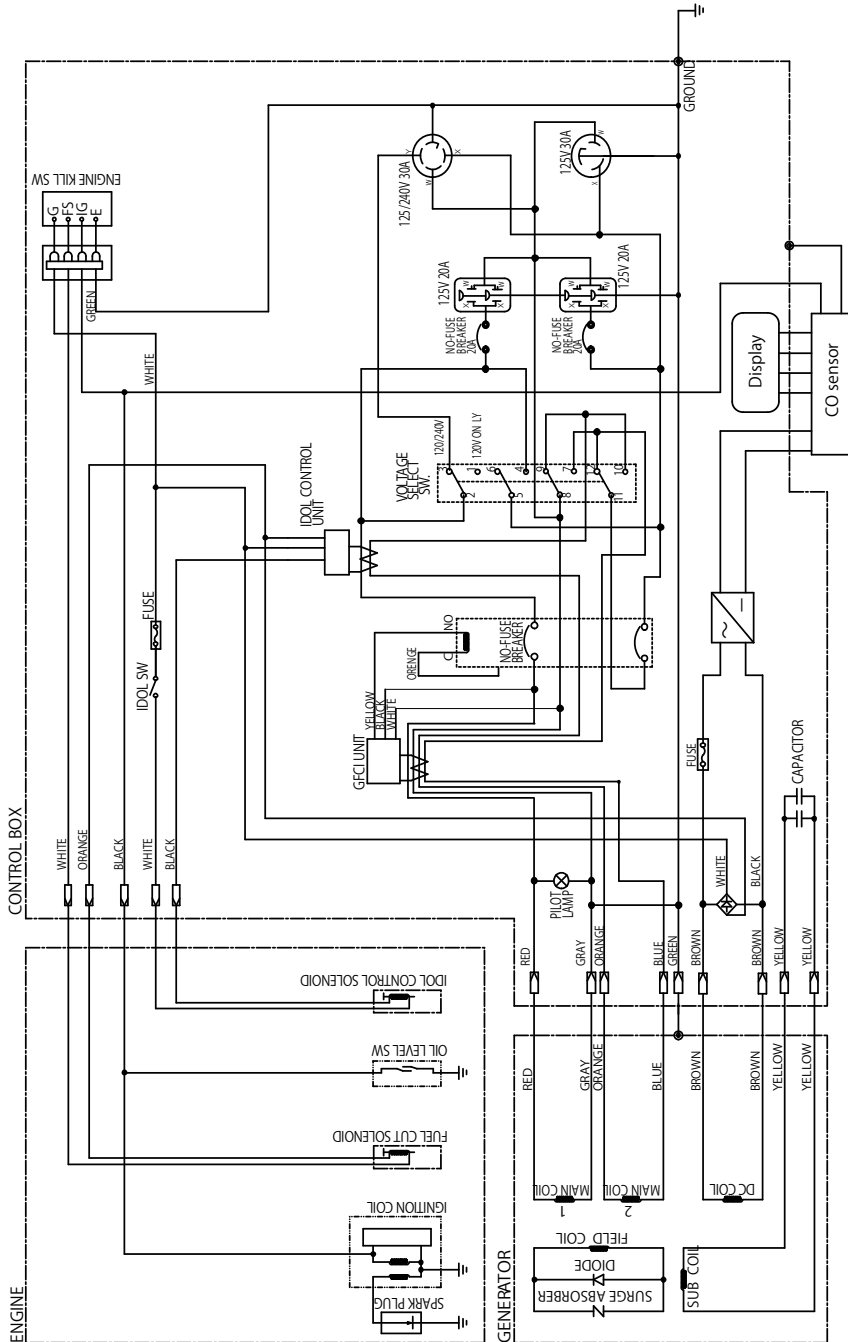

TPG4-6000~7500HDX

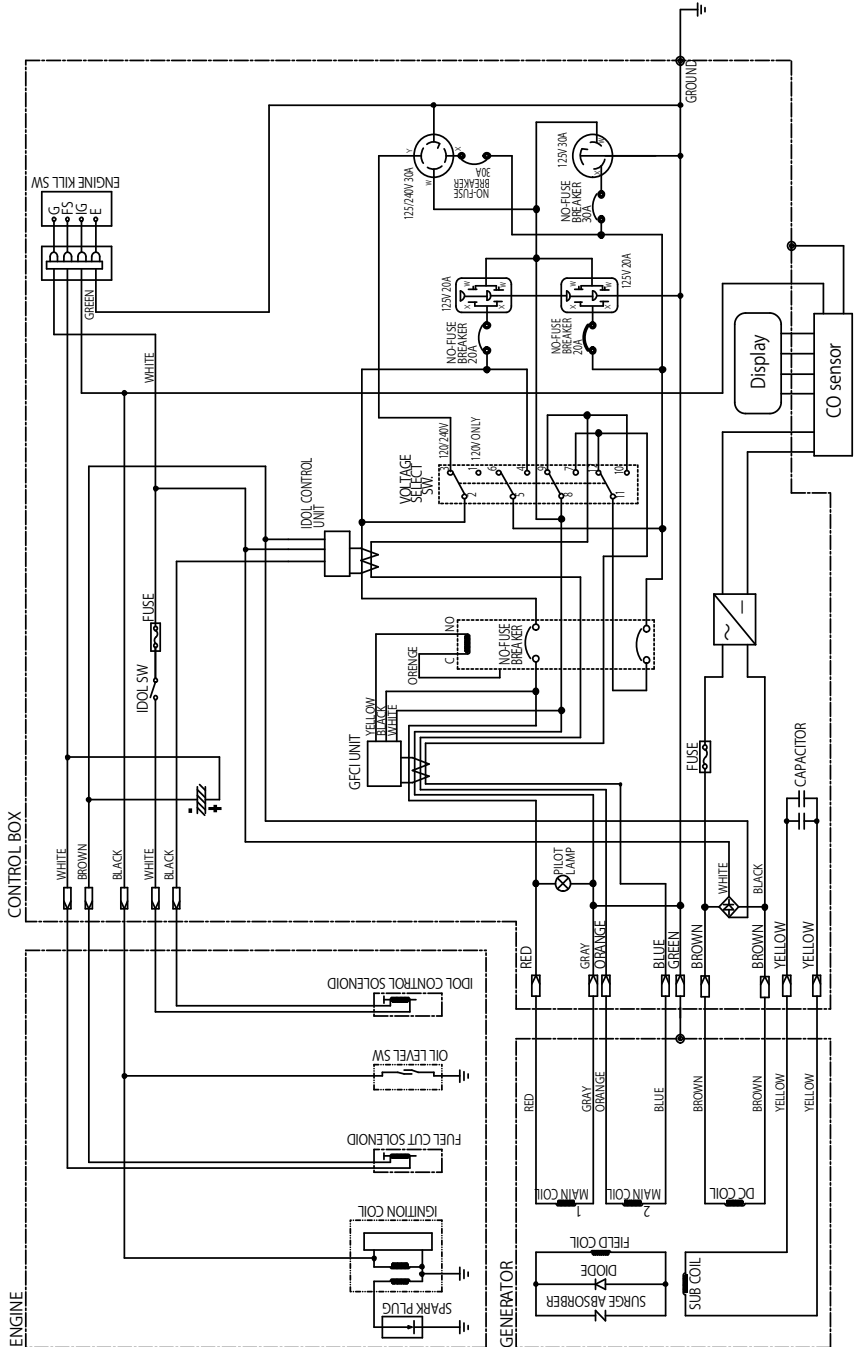

APPENDIX A

BATTERY ENCLOSURE KIT
ASSEMBLY AND INSTALLATION INSTRUCTIONS

FOR
TPG4-7000HDXE and TPG4-7500HDXE
PORTABLE GENERATOR

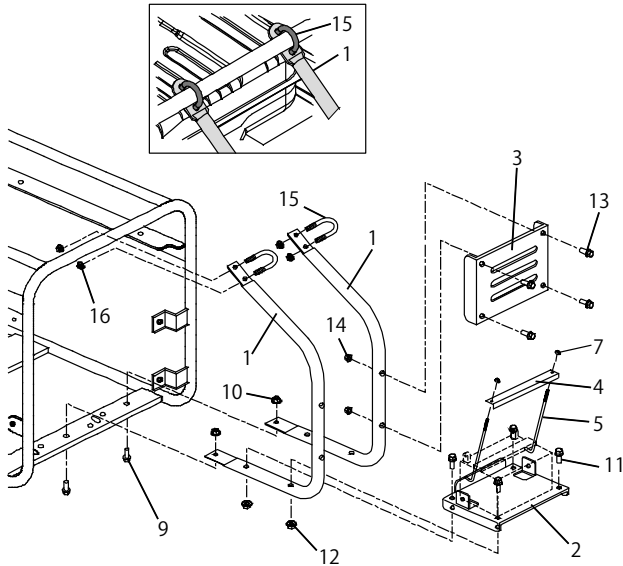

Ref.	Part No.	Description	Qty	Ref.	Part No.	Description	Qty
1	F200000260	Tube, Battery Support	2	10	022006000	Nut, Self-Locking(M8)	2
2	F080000300	Base Plate, Battery	1	11	0013706040	Bolt and Washer Assembly (Base Plate-to-Tube) (M8×35L)	4
3	F241000050	Plate, Battery Shield	1	12	0022006000	Nut, Self-Locking(M8)	4
4	F090000130	Plate, Battery Hold-down	1	13	0013706040	Bolt and Washer Assembly (Shield to Tube) (M8×35L)	4
5	F100000011	Rod, Hold-down	2	14	0022006000	Nut, Self-Locking(M8)	4
6	-----	-----	--	15		U-Bolt	2
7	0021506000	Nut(M6)	2	16		Nut, Self-Locking(M8)	4
8	-----	-----	--				
9	0013708020	Bolt and Washer Assembly (Tube-to-Frame) (M8X16L)	2				

CHECK KIT CONTENTS

Check to make sure the parts listed above are included in the kit.
Contact Tsurumi to obtain any missing parts.

ASSEMBLY OF BATTERY ENCLOSURE

- Align holes in base plate (2) with holes in battery support tube (1).
Install two bolts (9) and two nuts(10).
- Repeat step 1 for second battery support tube (1).
- Align holes in plate (3) with holes in battery support tubes (1).
Install four bolts (13) and four nuts(14).

Tighten all fasteners.
- Attach the top of the battery support tube in two nuts(16) of the U-bolt(15).
- Repeat step 4 for second battery support tube (1).

INSTALLTION OF BATTERY ENCLOSURE

1. Position assembled enclosure on crossover support on bottom of generator frame. Install two bolts (11) through support tubes (1) and generator frame. Install and tighten nuts (12).
2. Align holes in support tubes (1) with holes in upper frame. Install two bolts (13) and nuts (14).
3. Check to make sure all bolts and nuts are tight.

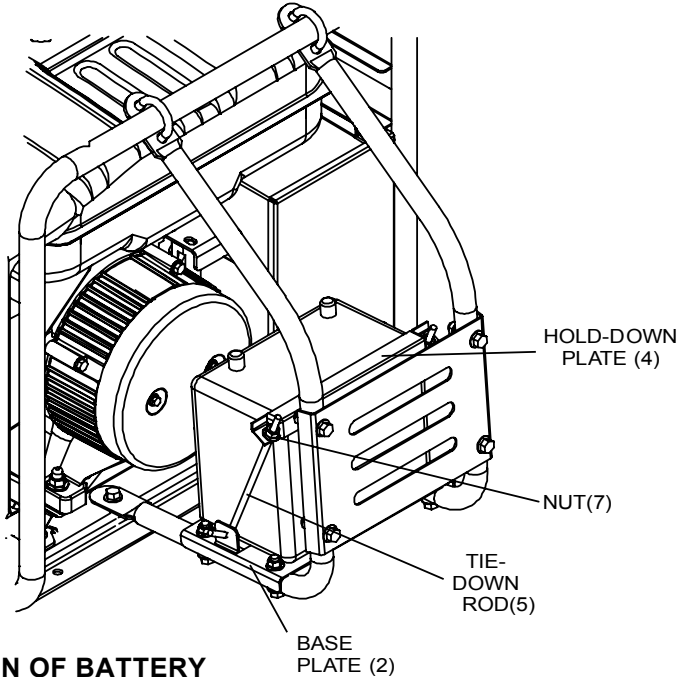

INSTALLTION OF BATTERY

1. Set battery on base plate (2). Place hold-down plate (4) on front edge of battery.
2. Install hooked end of tie-down rods (5) in holes in base plate (2). Put threaded ends of tie-down rods (5) up through holes in hold-down plate (4).
3. Install nuts (7) on tie down rods. Tighten wing nuts (7).
4. Connect battery cables to terminals.
5. Start the generator to verify that the battery is properly connected.

NOTE:

The model TPG4-7000HDXE and TPG4-7500HDXE generator has a 12-volt DC starting system.

Use a 12-volt, garden tractor-type battery as a replacement battery.

