



 **TSURUMI PUMP**™
BUILT FOR WORK®

MMR

SERIES

IE3 PREMIUM EFFICIENCY MOTOR
EXPLOSION PROOF

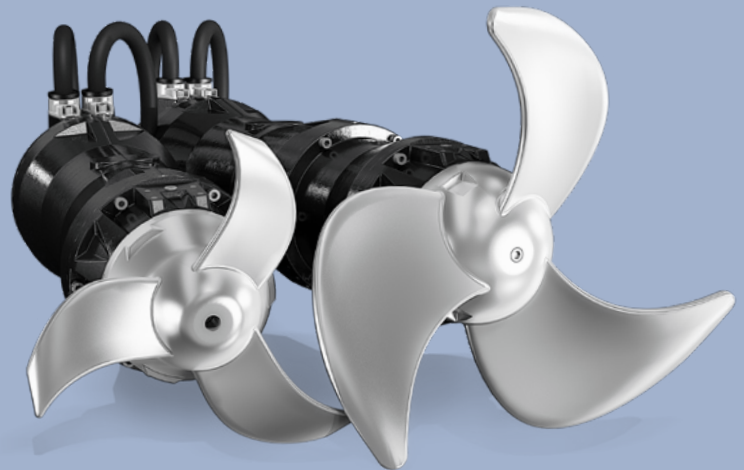



The **AVANT MMR Series** is a new offering of submersible pumps developed by Tsurumi Pump, a leader in the pump industry since 1924. The **AVANT MMR Series** mixers feature FM approved premium IE3 motors. They have been designed to operate over a wide range of conditions. Optional motor and mounting configurations available. The **AVANT MMR Series** can offer a mixer for a wide range of applications.

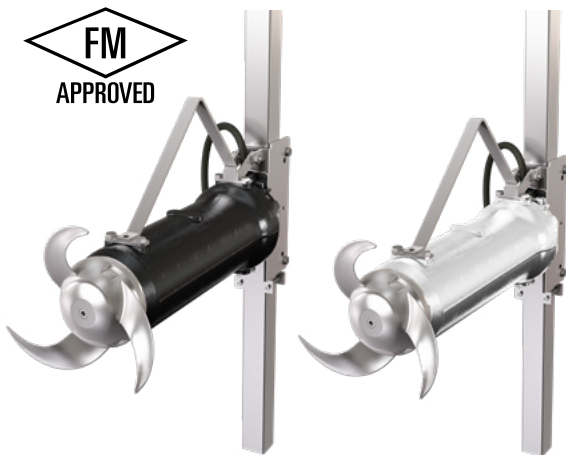

MMR Series

Cast iron – Premium efficiency IE3 motors

DIRECT TRANSMISSION

- Propeller Ø 200 - 300 - 400 mm
- Motor power 1-6 hp
- 4, 6, and 8 pole motors

REDUCTION GEARS

- Propeller Ø 650 mm
- Motor power 5-10 hp
- 4 pole motors

Stainless steel type available (Option)

The **AVANT MMR Series** submersible mixers feature IE3 premium efficiency motors. These durable compact mixers come standard with EN-GJL-250 cast iron body, AISI 316 stainless steel propeller, and AISI 431 stainless steel shaft.

Additionally, The **AVANT MMR Series** features silicon carbide dual mechanical seals. As an option, models are also available with a stainless steel body made of AISI 316. The **AVANT MMR Series** provides a high level of reliability and stability. The **AVANT MMR Series** features propeller sizes from 200-650 mm and motor outputs from 1 - 10 hp. A variety of accessories are available for installing the mixers in new or existing applications.

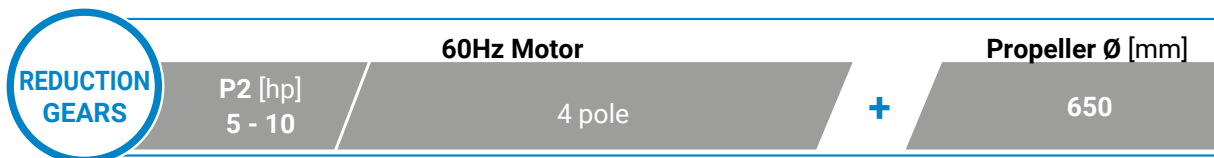
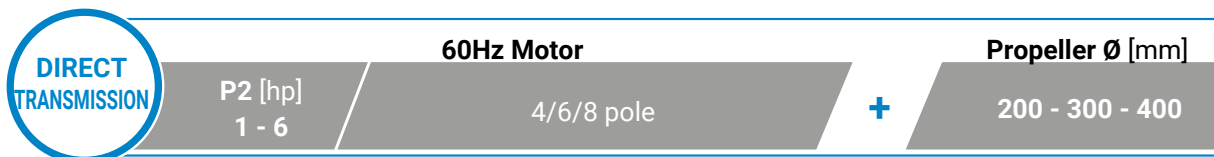

Characteristics of MMR Series

- Innovative cable gland system with cable holder. The universal thread ring-nut can be removed to fix a rigid or flexible conduit to the cable gland to protect the cable from physical stresses.
- Premium efficiency IE3 class motors with class H insulation (356°F).
- Two silicon carbide (SiC) mechanical seals. Gear reduced models have a third SiC seal located in the gearbox.
- Cast AISI 316 stainless steel propeller, designed to ensure high hydraulic efficiency and prevent fouling with filaments and solids found in heavy duty applications.
- The AVANT MMR Series mixers are equipped with thermal sensors embedded on the stator windings that prevents the motor from overheating. For further protection, the leakage sensor is installed inside the oil chamber, allowing the detection of water intrusion.
- Wide range of stainless steel accessories for optimal positioning in new installations or when replacing existing devices.

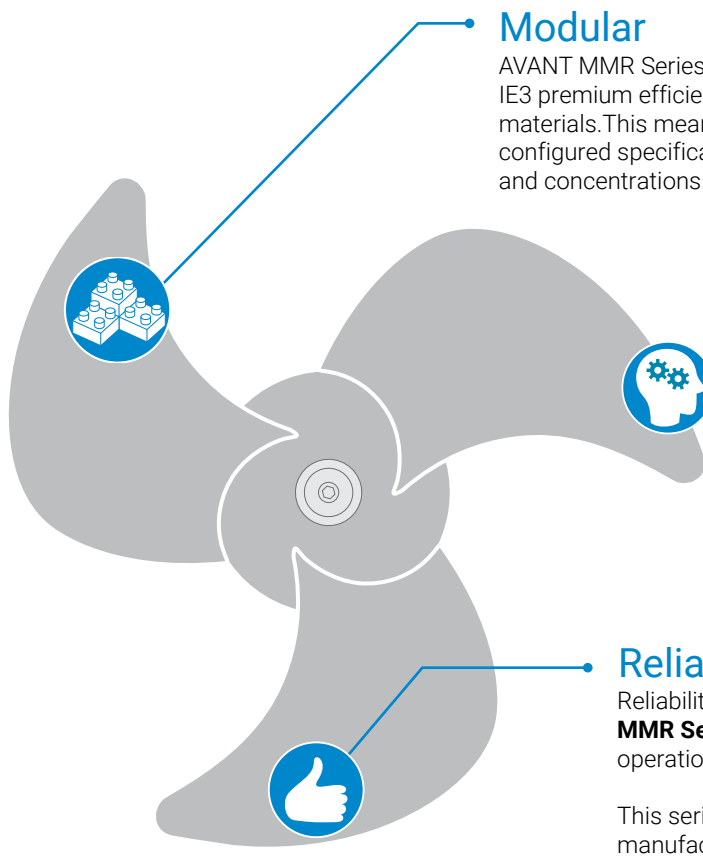

Modular
 AVANT MMR Series mixers are built with the end user in mind. It combines IE3 premium efficiency motors with propellers of different shapes, sizes and materials. This means greater flexibility when selecting the product, which can be configured specifically for the application, and for liquids with different densities and concentrations.

Innovative
 Innovation, defined as making changes to the established norms, introducing new ideas and product improvements.
 The **AVANT MMR Series** meets this definition by using IE3 motors, operating over a wide range of conditions.

Reliable
 Reliability, the quality of performing consistently well. The **AVANT MMR Series** is designed and manufactured for years of trouble-free operation with low maintenance costs.
 This series is the result of advanced design, state of the art manufacturing facilities and a proven assembly process.



Features

The **AVANT MMR Series** of mixers offers a wide range of solutions for wastewater treatment plants. They can be in aerobic/anaerobic/anoxic stages of wastewater treatment processes, preventing sedimentation and maintaining constant concentration levels in the tanks. Propellers for mixers are sized, shaped and driven at speeds designed to match the site requirements.

MOTOR

Premium IE3 class motors for high efficiency and minimal energy use. Insulation class H (356°F).

MECHANICAL SEALS

Two silicon carbide (SiC) mechanical seals.

Gear reduced models have a third SiC seal located in the gearbox.

PROPELLER

Cast AISI 316 stainless steel propeller, designed to ensure high hydraulic efficiency and prevent fouling with filaments and solids found in heavy duty applications.

A special chopper system in the rear of the propeller prevents the entry of filaments. This feature stops entanglements around the shaft.

MONITORING

The **AVANT MMR Series** mixers are equipped with thermal sensors embedded on the stator windings that prevent the motor from overheating. For further protection, the leakage sensor is installed inside the oil chamber, allowing the detection of water intrusion.

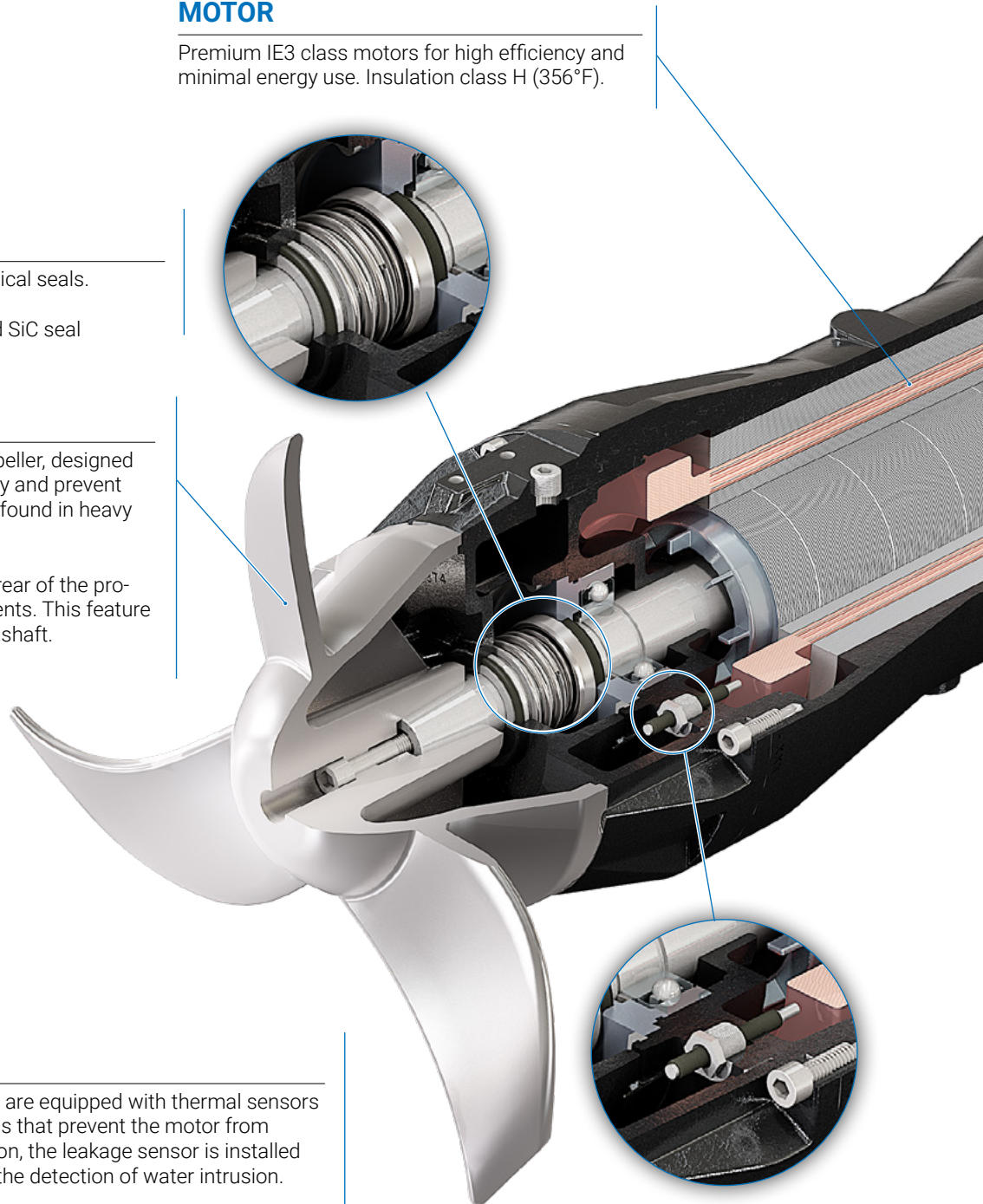



CABLE GLAND

Innovative cable gland system with cable holder. The universal thread ring-nut can be removed to fix a rigid or flexible conduit to the cable gland to protect the cable from physical stresses.

INSTALLATION

Wide range of stainless steel accessories for a variety of installation options for both existing and new applications.

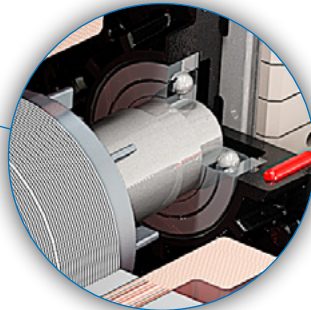

BEARINGS

Ball bearings with lifetime lubrication designed for 100,000 working hours. Temperature sensor on request.

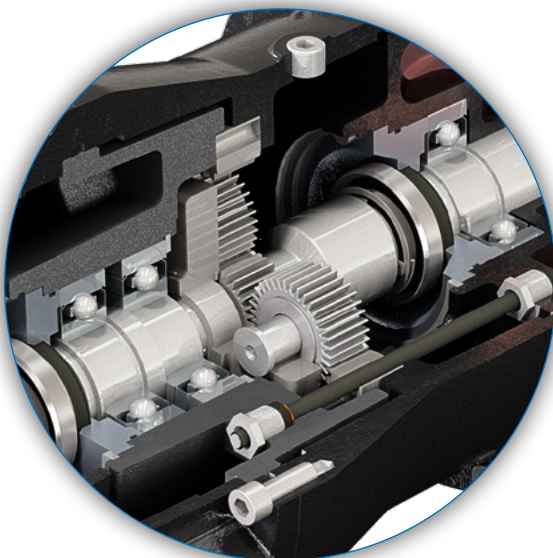

REDUCTION GEARBOX

Planetary reduction gearbox provides high reduction ratios and torque transfer. Able to withstand heavy radial loads in a lightweight and compact design.

Specifications

Direct Drive

Model	Motor Output (hp)	Rated Current (A)		*S.S. (rpm)	Reduction Ratio	Output Speed (rpm)	Propeller Diameter (mm)	Thrust (lbf)	Weight (lbs)	Mounting Bracket (in.)	Dimensions (in.)		
		230V	460V								L	W	Dia.
MMR21NF41.1D-6	1.5	4.8	2.4	1800	-	1800	200	51	78	2 x 2	18 5/8	7 7/8	8 1/4
MMR21NF41.5D-6	2	6.6	3.3	1800	-	1800	200	52	80	2 x 2	18 5/8	7 7/8	8 1/4
MMR33NF61.5D-6	2	6.6	3.3	1200	-	1200	300	94	106	2 x 2	26 5/8	18 5/8	11 7/8
MMR31NF62.2D-6	3	9.8	4.9	1200	-	1200	300	136	126	2 x 2	30	18 5/8	11 7/8
MMR32NF63.2D-6	4	12.6	6.3	1200	-	1200	300	164	175	2 x 2	32	20 3/4	12
MMR42NF84.5D-6	6	18.8	9.4	900	-	900	400	218	272	4 x 4	37 1/2	38 7/8	15 3/4

*Synchronous Speed

Gear Reduced

Model	Motor Output (hp)	Rated Current (A)		*S.S. (rpm)	Reduction Ratio	Output Speed (rpm)	Propeller Diameter (mm)	Thrust (lbf)	Weight (lbs)	Mounting Bracket (in.)	Dimensions (in.)		
		230V	460V								L	W	Dia.
MMR61NF44.0G072-6	5	14.8	7.4	1800	7.2	250	650	0.31	320	4 x 4	47 1/2	38 7/8	25 5/8
MMR61NF45.5G066-6	7	19.8	9.9	1800	6.6	273	650	0.34	327	4 x 4	47 1/2	38 7/8	25 5/8
MMR61NF47.5G058-6	10	25.6	12.8	1800	5.8	310	650	0.47	406	4 x 4	48 1/2	39 3/4	25 5/8

*Synchronous Speed

Materials

	Standard	Optional
Motor Housing	EN-GJL 250 gray cast iron	AISI 316 stainless steel
Propeller	AISI 316 stainless steel	Duplex / With Vulkollan coating
Shaft	AISI 431 stainless steel	-
Mechanical seals	Silicon carbide	-
Hardware	A2-70 Stainless Steel	A4 stainless steel
Gaskets	NBR	Viton
Lifting Hook	AISI 304 stainless steel	AISI 316 stainless steel
Motor bracket	AISI 304 stainless steel	AISI 316 stainless steel
Paint	Bicomponent epoxy paint 7.8 thou	Bicomponent epoxy paint 15.7 thou

Operating limits

Max. ambient temperature	104°F
Max. immersion depth	65 ft
pH of treated liquid	6 to 12
Max. starts/hour	15
Max. acoustic pressure	70 dB
Duty	S1 – continuous operation
Density of treated liquid	66 lb/ft ³
Max. dynamic viscosity	500 cP

Accessories

The **AVANT MMR Series** offers a wide range of accessories for adjusting the mixer's position in the tank. With assistance from lifting equipment, these accessories are designed for easy installation, positioning, and removal of the mixer. Accessories are available in galvanized or stainless steel.

The recommended installation methods are:

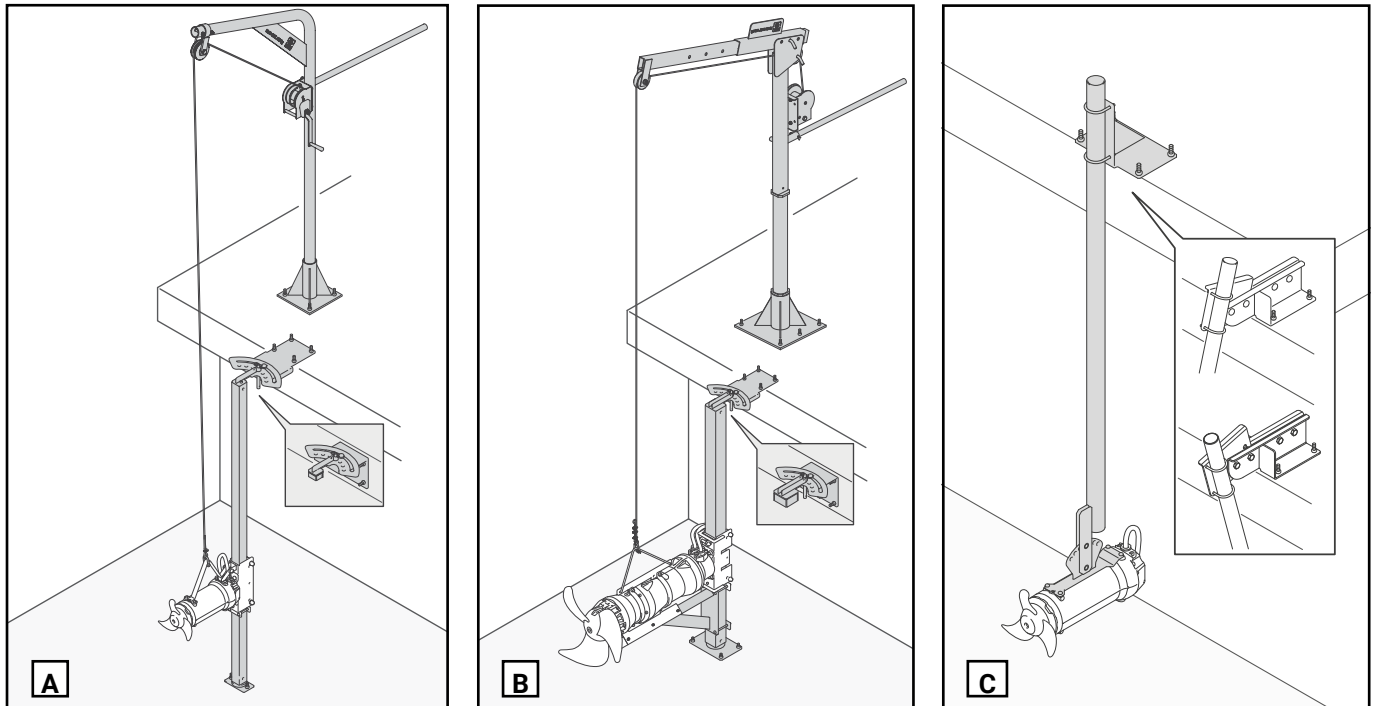

Mast installation (fig. A and B)

The most common installation type for mixers of any shape and size. The mixer, fitted with a universal mounting bracket, slides along a square post for easy removal and required horizontal positioning. Vertical adjustments can be made with an additional mounting bracket.

Pendular installation (fig. C)

Installation in which the mixer can be both installed and removed while the tank is full. The mixer is suspended from a pipe that is fixed to a mounting bracket. It can be adjusted both horizontally and vertically.

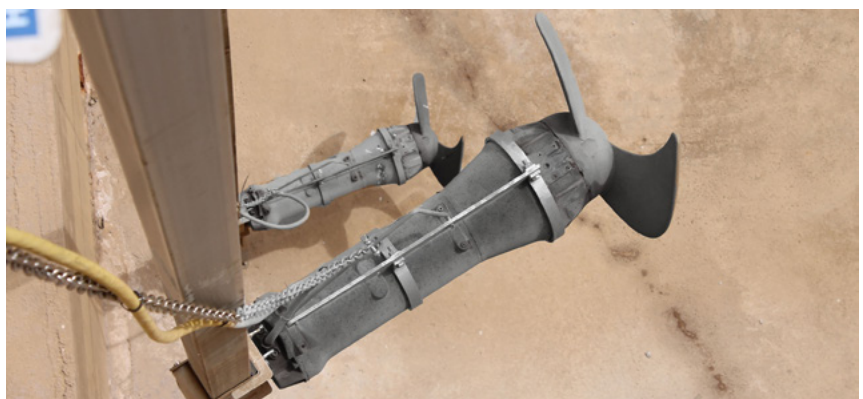

Product colors may vary in actual appearance, features are highlighted for illustrative purposes.



Headquarters: 1625 Fullerton Ct, Glendale Heights, IL 60139
Utah Office: 3822 West 1987 South, Salt Lake City, UT 84104
Tel: 1-888-878-7864 (Toll-Free) • 1-630-793-0127
www.tsurumipump.com