

SEAL LEAK SENSOR: 30 - 400 HP

Figure 1

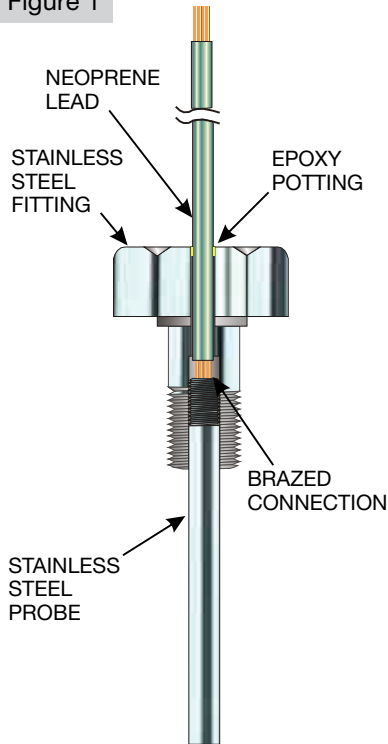

On select 30-400 HP pumps, Tsurumi features an internally mounted seal leak sensor, (as shown in **Fig. 1**).

It is a probe type sensor that senses the incursion of water into the oil chamber which houses the mechanical seal. The seal sensor is mounted as shown in **Fig. 2**.

Sequence of Operation

The seal leak sensor works in conjunction with a seal leak relay in the panel to notify excessive water in the oil chamber. The seal leak sensor provides a reference point along with pump ground for measuring conductivity in the oil chamber. At the point at which the conductivity of the water exceeds the conductivity set point of the seal leak relay, an alarm indicator on the door of the panel will illuminate. Additional alarm configurations available upon request (audible alarm, auto-dial, pump shutdown) .

Figure 2 **SEAL SENSOR**

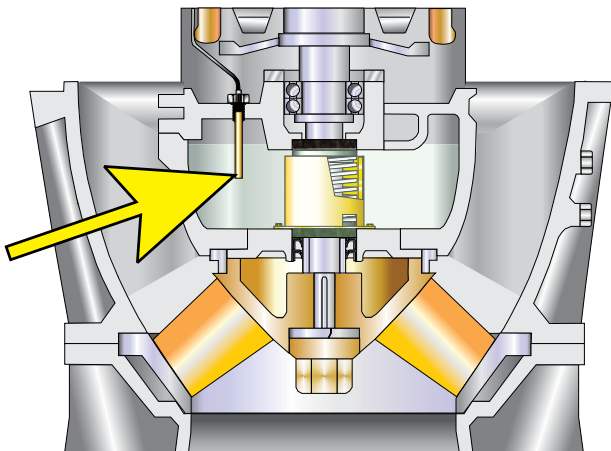
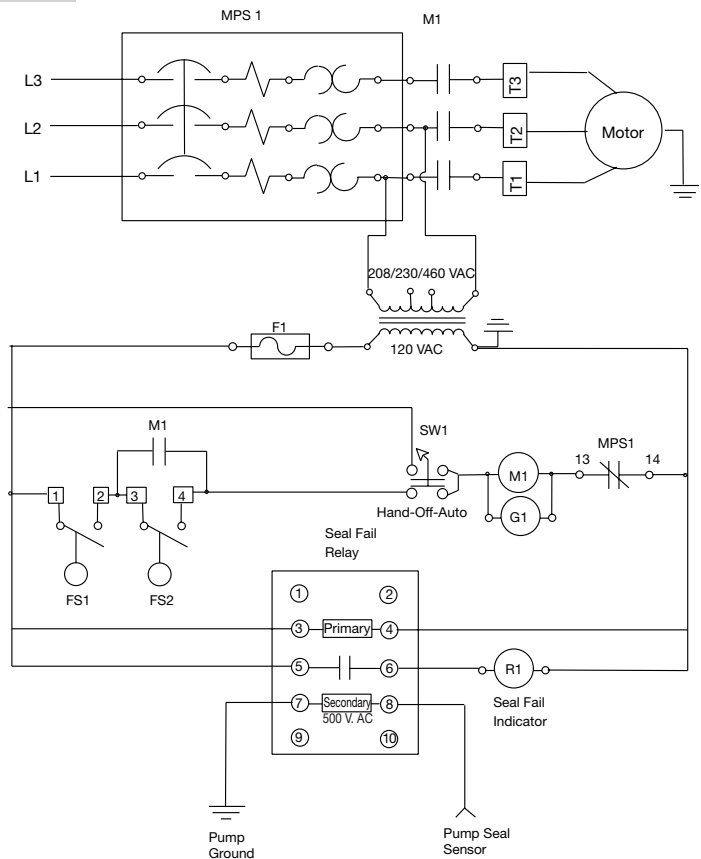

Figure 3 **TYPICAL WIRING DIAGRAM**



Note: Must be installed in accordance with all National or Local Electrical or Building Codes.